



INSTRUCTIONS BOOKLET FOR INSTALLATION, USE AND MAINTENANCE

GAS FIRED CALORIFIER



INSTRUCTIONS BOOKLET
FOR INSTALLATION, USE AND MAINTENANCE

GAS FIRED CALORIFIER





Dear Customer,

Thank you for choosing a Gas Fired Calorifier by VERSOL GROUP.

In your interest and to maintain the highest level of performance and duration of your appliance, we recommend that you follow the instructions contained in this booklet and have regular maintenance performed by qualified personnel.

We would like to remind you that failure to follow the instructions contained in this booklet may invalidate the guarantee





CONTENTS

GENERAL NOTES	PAGE-03
OFFLOADING, LIFTING AND SITING PROCEDURES	PAGE-03
GENERAL CHECKS PRIOR TO INSTALLATION	PAGE-06
INSTALLATION	PAGE-08
COMMISSIONING AND OPERATION	PAGE-10
MAINTENANCE	PAGE-12

GENERAL NOTES

1.1 DESCRIPTION

This manual covers the installation, Operation & Maintenance of Gas Fired Calorifiers under VERSOTHERM range. These instructions should be read and understood prior to commencing with the works and during the operation of the units

1.2 SAFETY

Operators installing the equipment should be given adequate training prior to installation works. Correct PPE should be worn to ensure safety whilst operating on the units. All works undertaken as listed below shall be the responsibility of the contractor.

OFFLOADING, LIFTING AND SITING PROCEDURES

2.1 OFFLOADING

The VERSOL Storage Calorifiers shall be lifted and moved using the lifting lugs provided on the Calorifier shells. Prior to offloading or removing, the units should be inspected to ensure no damage has occurred during transit. Care should be taken not to damage the insulation cladding while offloading and moving the units.

Once offloaded, the units should be inspected to ensure no damage and all items are supplied as ordered.

The units can be stored as it is either Vertical/Horizontal till transported to the plant room or can be shifted to its original orientation before shifting which ever suits site conditions.

Connect straps "A1 and A2"
Unload with the supporting base frame

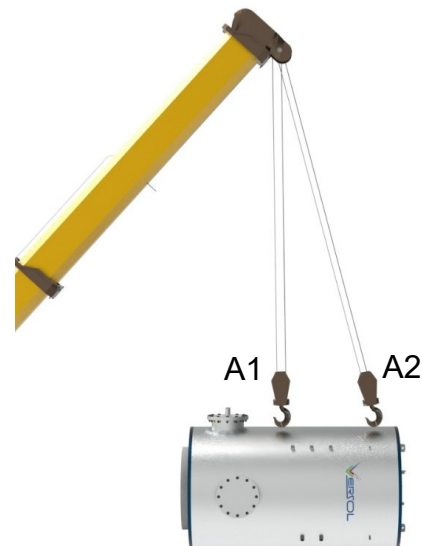

2.2 LIFTING

Use lifting eyes where fitted. Do not lift a Calorifier using the insulation (if fitted). Straps may crush the insulation. The shell of the Calorifier may be made of relatively light gauge metal and care should be exercised when handling and moving the unit not to damage the shell. Do not lift the Calorifier using chains directly in contact with the shell. Do not allow operatives to stand on the Calorifier

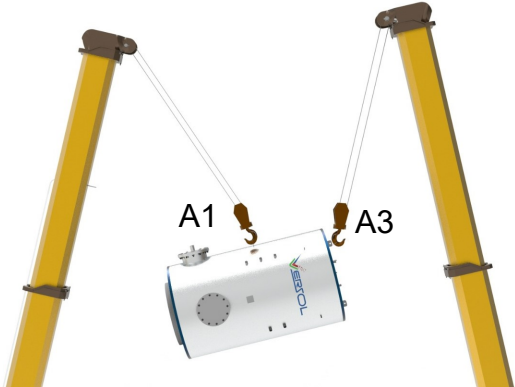
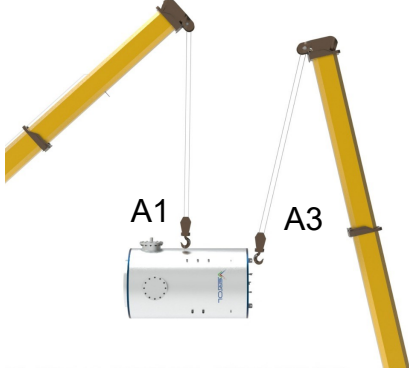
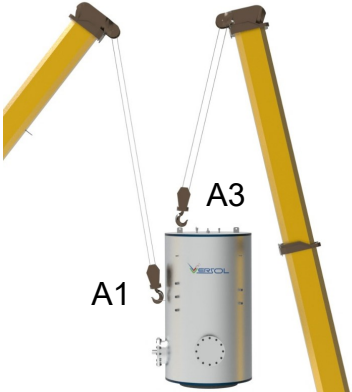
<p>1. Connect straps "A1 and A3" Gradually lift "A1 and A3" 1 meter Height</p>	
<p>2. Slow lift "A3 and A1"</p>	
<p>3. Make vertical position and remove the base frame</p>	

2.3 SITING

Unless specifically ordered for an external installation, the calorifiers must be sited indoors.

Foundations or plinths must be firm and level to prevent settling, pipe strain or distortion of the shell.

Unless specifically ordered differently, the vessel must be installed in a level position.

Calorifier shall be shifted to plant room and place in the plinth carefully.

Calorifier and other equipment's should at least have a minimum 500mm distance gap in between each other for future maintenance and servicing.

Calorifier side where there is a removable burner connected should at least have a minimum 1500mm distance gap in between other items for future maintenance and servicing.

GENERAL CHECKS PRIOR TO INSTALLATION

3.1 GENERAL

Protective covers and plugs may be fitted to connections to protect them in transit. These must be removed prior to use.

If a connection is not required, seal it appropriately.

Check for any foreign material which may have got into the vessel.

Pipework connected to the vessel must be adequately supported to prevent any loads being transmitted to the vessel.

Provide for thermal expansion with bends and expansion joints

3.2 BURNER TUBES BUNDLE AND BURNER

The burner tubes bundle and burner are tested before leaving the factory and are ready for installation.

The burner tubes bundle and burner is tested for the performance and the pressure rating as mentioned in the test report & name plate.

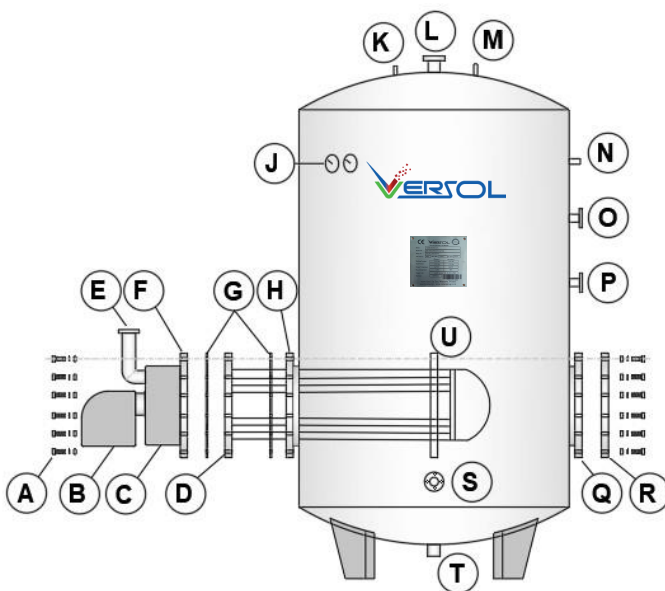

CALORIFIER ITEMS - CONNECTIONS	
A	NUT BOLT WASHER SET
B	BURNER
C	HEAD COVER
D	TUBE SHEET
E	CHIMNEY
F	HEAD COVER FLANGE
G	GASKET
H	CALORIFIER BURNER FLANGE
J	PRESSURE - TEMPERATURE GAUGES
K	AIR VENT
L	HOT WATER SUPPLY
M	SAFETY VALVE
N	SENSOR
O	SUPPLY FROM SOLAR STORAGE CALORIFIER
P	HOT WATER RETURN
Q	CALORIFIER MANHOLE FLANGE
R	MANHOLE COVER FLANGE
S	COLD WATER SUPPLY
T	DRAIN
U	SUPPORT LOOP

LEGEND	
1	MANUAL ISOLATION VALVE
2	FILTER
3	PRESSURE GOVERNOR
4	PRESSURE TEST POINT
5	GAS PRESSURE SWITCH
6	SAFETY VALVE
7	CONTROL VALVE
8	PRESSURE COUPLING TEST POINT
9	GAS SUPPLY TO BURNER CONN
10	GAS BURNER
11	GAS FIRED BOILER

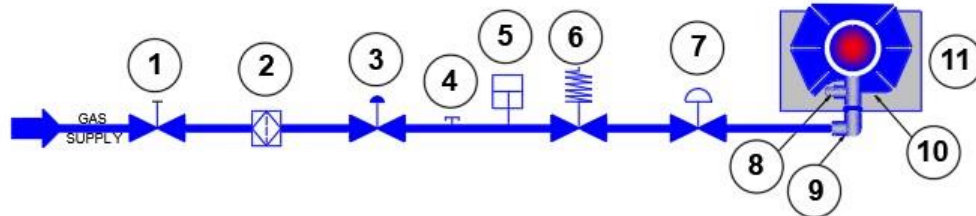

Typical gas supply piping to burner with associated valves and accessories.

NOTE: Gas supply piping to burner may vary as per requirements.

3.4 CONTROLS

Prior to commissioning, burner gas supply connection and wiring to the burner, check all the control circuitry and main circuit connections are tight using the appropriate tools.

Remove all loose items from inside the panel and other items that may be fastened to the cables.

The equipment must be connected to a suitable power supply in accordance with local regulations and the wiring diagram supplied.

The burner gas supply must be connected to suitable requirements of the burner specification and must be in accordance with local regulations and the wiring diagram supplied.

To avoid damage to the burner and burner tubes bundle and other associated items do not allow the system to run dry.



INSTALLATION

4.1 The calorifiers should be installed in a suitable position to ensure maintenance can be carried out on the Calorifiers.

Adequate space should be allocated around the calorifiers to ensure suitable access to the inspection opening, control panel and also to withdraw the burner from the calorifiers.

Calorifier to other equipment should at least have a minimum 500mm distance gap in between each other for future maintenance and servicing.

Calorifier side where there is a removable tube heat exchanger, burner or electric heater should at least have a minimum 1500mm distance gap in between other items for future maintenance and servicing.

4.2 The unit should be flushed prior to connecting of pipe work, valves and ancillaries.

4.3 Fit isolation valves prior to the vessel connections to facilitate servicing (NOT TO THE VENT).

For flanged connections, tighten bolts in a diametrically opposite sequence to load the flanges evenly onto the gasket. Ensure adequate venting for air removal during filling and operation (pressurized systems should have an automatic air vent and a manual air vent for this).

Safety valves should have their discharge pipes away to a safe disposal point, preferably via an air-break and tundish so that the discharge unrestricted and easily visible.

Water expansion must be accommodated by a separate expansion vessel fitted in the system.

GAS FIRED CALORIFIER CONNECTION DETAILS

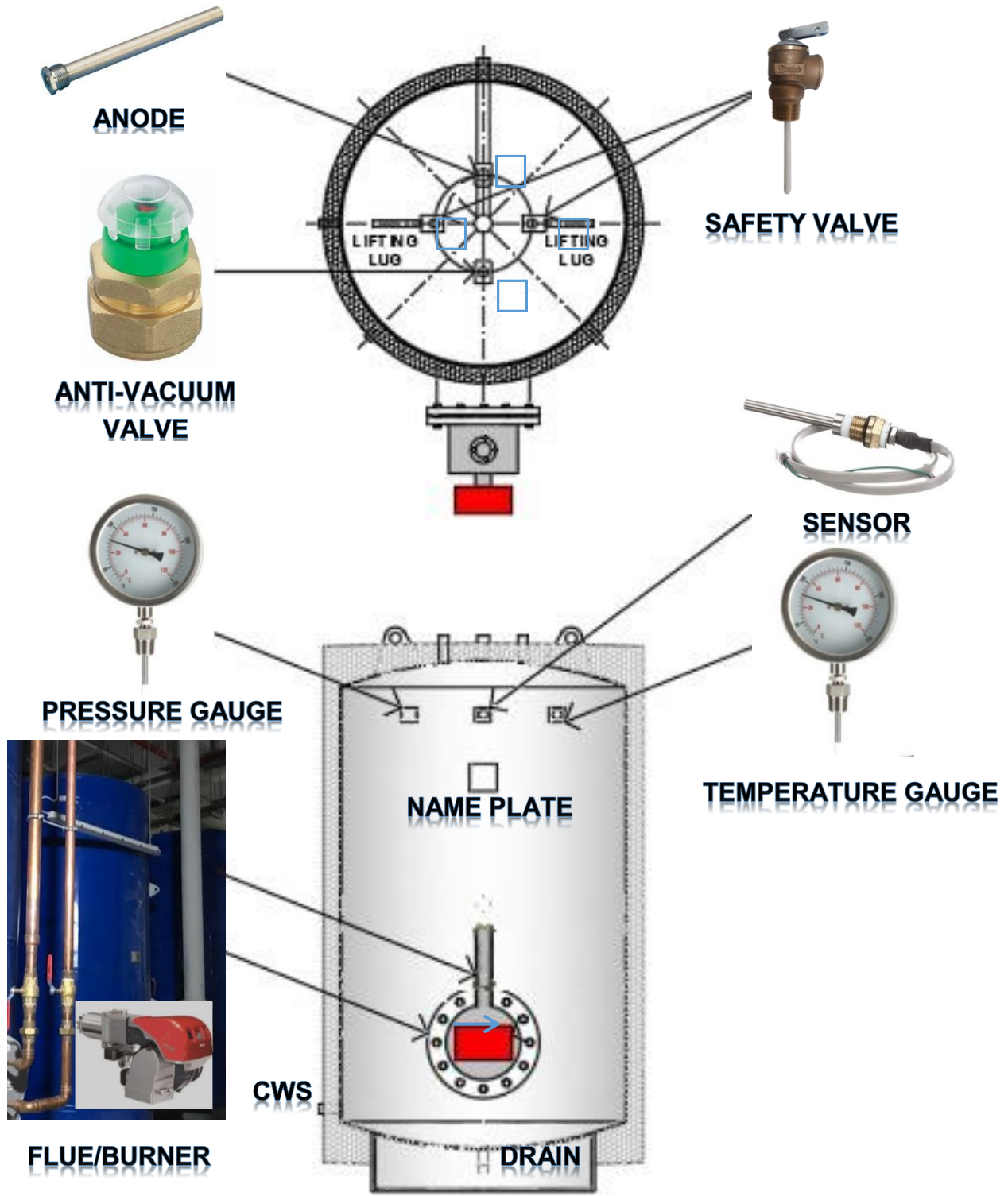

COMMISSIONING AND OPERATION

5.1 Do not operate the equipment at pressures or temperatures in excess of those specified on the nameplate of the vessel marking.



Allowable Pressure

Do not subject the equipment to conditions of vacuum or partial vacuum. This is particularly vital for copper-lined steel calorifiers, which are supplied complete with anti-vacuum valve which must not be removed from the unit. For example partial vacuum can be caused if the cold feed or the vent are restricted during draw off or drain down.

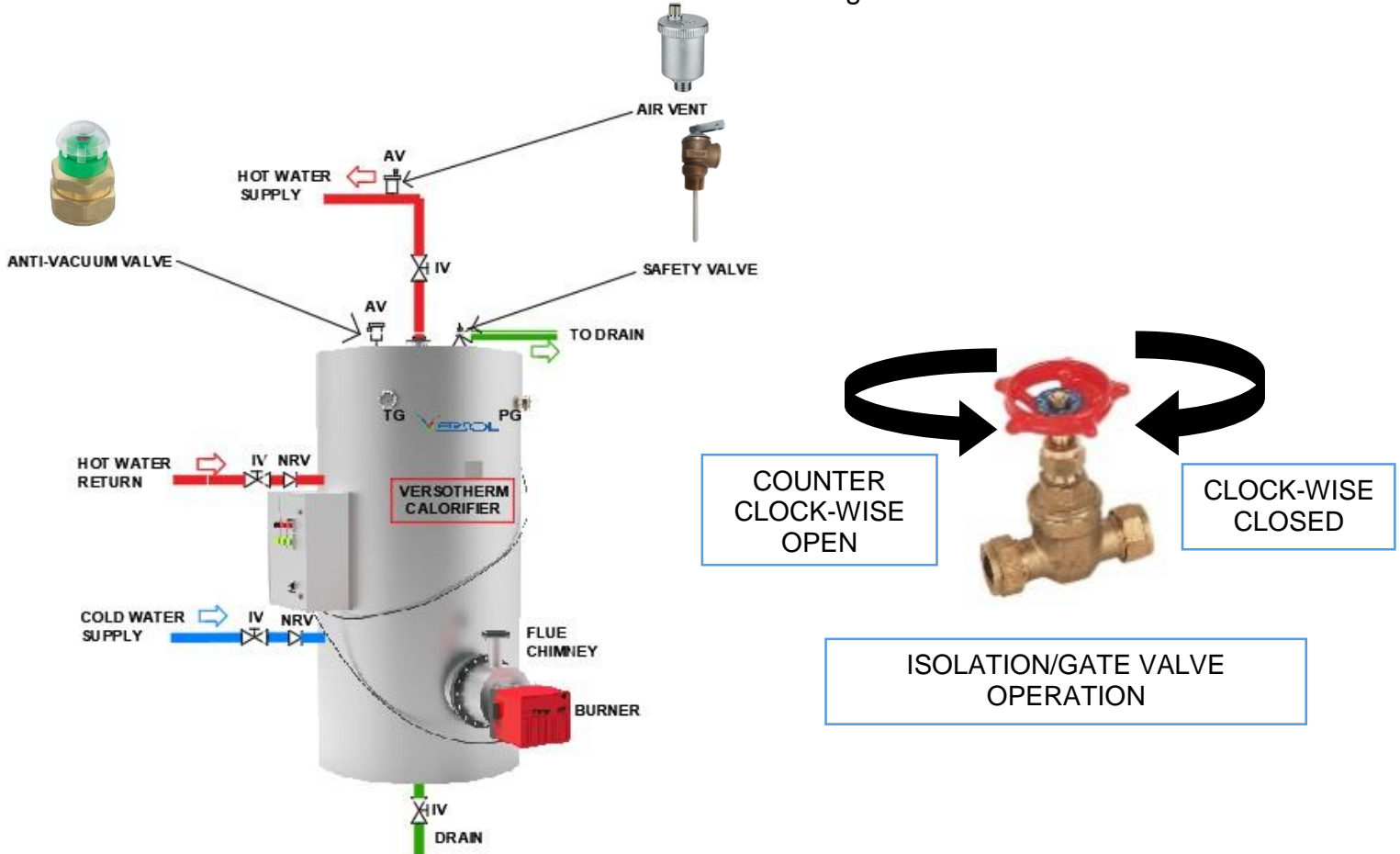

5.2 It is assumed here that the secondary pipework is already full of water.

5.3 For sealed systems it is assumed here that any cold water booster set and/or pressure reducing valve is already commissioned and set to the correct pressure.

5.4 Start with hot water supply, hot water return, cold water supply and gas supply to burner valves closed, and building hot water return pumps and burner is at off state.

5.5 Make sure burner and building hot water return pumps are ready to turn on from main control panel with verified rotation.

5.6 For sealed systems ensure auto-air vent is operational.

5.7 Make sure control Panel is in off position.

5.8 Start filling of secondary pipe line, close the drain valve (if open), Open the hot water supply, hot water return and hot water supply isolation valves.

5.9 Make sure anti vacuum valve and safety valve installed in the storage calorifier are operational.

5.10 Make sure air installed in the storage calorifier hot water supply main header are operational.

5.11 Open the safety valve lever manually while filing the storage calorifier until water comes out of the safety valve on the top connection, close safety valve and cross check gauge for rated pressure in vessel.

5.12 Switch building hot water return pumps power on.

5.13 When the calorifier is full, it is ready to start heating.

5.15 Maintain the selector switches / MCB of Burner in off position.

5.16 Slowly open the gas supply isolation valve.

5.17 Make sure gas supply pressure to burner is as per requirements and all associated valve & accessories are installed in the gas supply piping as per requirements.

5.18 Turn on the burner for 30 second and check the gas suction, ignition and combustion then turn off.

5.19 Turn on the burner after 60 second and allow it to work up to 1 minute, gradually raising the running time up to 3 minutes in full stretch if function is normal.



-
- 5.20 If burner functions normally with proper combustion, put burner control in Auto Mode.
- 5.21 Check the system is reaching set point and turning off automatically.

MAINTENANCE

6.1 The VERSOL Storage Calorifier is designed to operate efficiently with a minimum of attention. A regular maintenance program will ensure continued high operating efficiency and trouble-free operation.

Annual maintenance should include cleaning debris from the base of the calorifier to comply with guidelines on prevention of legionella bacteria proliferation.

Also the site insurers may require annual inspection of burner, burner bundle tubes and calorifier shell condition.

6.2 - It is recommended that a set of gaskets be carried for use when the unit is stripped down for insurance inspection, or cleaning.

6.3 - Maintenance of the pump and other ancillary equipment should be carried out in accordance with the instructions supplied for these items by their respective manufacturers. Copies of these are included with these instructions.

6.4 To drain the Vessel,

6.5 Obtain a complete set of replacement gaskets from VERSOL local Representative.

6.6 For sealed systems reduce the residual calorifier pressure by manually operating the safety valve - some hot water will come out.

6.7 For sealed systems open a manual vent valve to allow air in during drain-down.

6.8 For copper-lined steel Calorifiers ensure that the anti-vacuum valve is not stuck shut - also ensure that a vent is available at the top of the calorifier of flow area at least one half the flow area of the drain connection.

Remove one of the fittings on the top of the calorifier if necessary to achieve this. Partial vacuum, caused by inadequate venting of copper-lined Calorifiers during drain-down, will cause damage to the thin copper lining.

6.9 If the calorifier is open vented and shares a vent with other Calorifiers, isolate it from the common vent using the 3 way valve (it will now vent to atmosphere). Pipe the drain to a drain point and open the drain valve.

The calorifier shell internal condition can be inspected by removing the inspection cover to allow visual examination.

6.10 It is assumed here that all isolation valves (except drain) are open at the start.

6.11 Isolate the primary fluid inlet and outlet - switch off primary pump and heating medium if necessary.

6.12 Switch off hot water return pumps and isolate secondary return to calorifier

6.13 Isolate the secondary flow

6.14 Isolate the cold feed

6.15 Re-fit new gaskets and re-fill the Calorifier according to the commissioning instructions above.

7.0 Cleaning of Burner Bundle Tubes:

7.1 Because tube bundles are fairly tightly packed, chemical cleaning, e.g. using a suitable solution containing inhibitors to protect the metal, will generally give the best results.

7.2 Take care that the chemicals used will not cause any adverse or hazardous reaction with the materials of the tube bundle or the deposits being cleaned.

7.3 a) Cleaning in Place (CIP)

7.4 Disconnect and remove the gas supply line from burner and remove integral burner from the burner bundle tube

7.5 Remove the flue chimney and the head/cover

7.6 Take care not to damage any control capillary tubes.

7.7 Connect CIP hoses directly to the burner bundle tube and circulate cleaning chemicals as necessary.

7.8 Do not exceed normal burner bundle tubes flow-rate by more than 50%.

7.9 Fully remove all traces of cleaning chemicals by flushing with fresh water after the CIP process.

7.10 If the burner bundle tubes is to be removed from storage calorifier for external chemical cleaning.

7.11 Disconnect and remove the gas supply line from burner and remove integral burner from the burner bundle tube

7.12 Remove the flue chimney and the head / cover



7.13 Slowly pull / remove burner tube bundle (The tube bundle may be heavy).

7.14 Ensure that adequate facilities are available to withdraw the bundle without distortion or damage
(Avoid damaging surfaces of flanges).

7.15 When lifting or working on the tube bundle support it by the tube plates and the support plates ideally on wooden blocks cut to fit the curvature of the tube bundle.

7.16 The tube bundle must not be supported on the tubes.

7.17 Do not bend or distort supports and baffles.

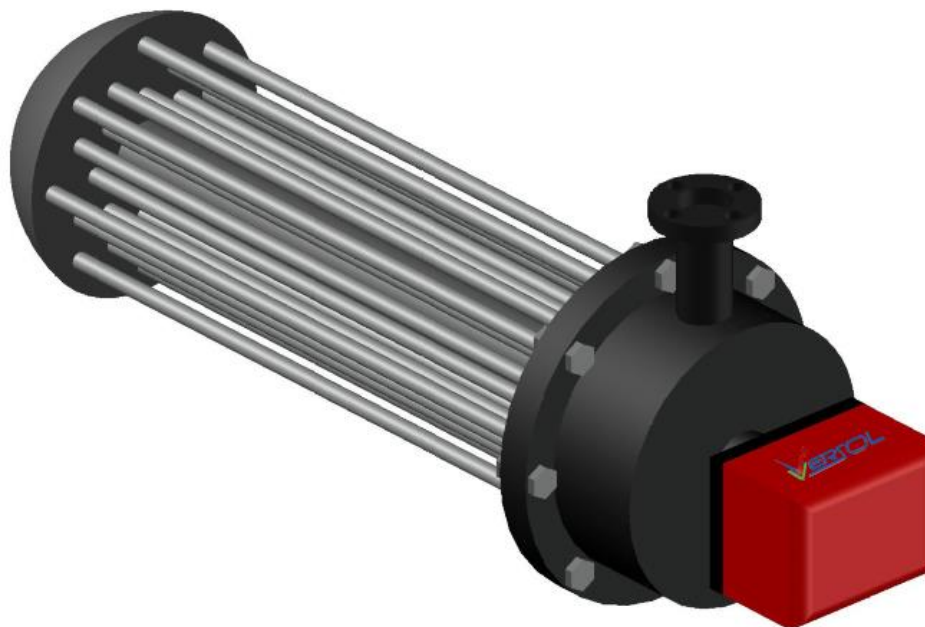



Versol Poland | Versol Italy | Versol UK | Versol USA | Versol Middle East | Versol India

