



INSTRUCTIONS BOOKLET
FOR INSTALLATION, USE AND MAINTENANCE

WATER SOURCE HEAT PUMP



INSTRUCTIONS BOOKLET
FOR INSTALLATION, USE AND MAINTENANCE

WATER SOURCE HEAT PUMP



Dear Customer,

Thank you for choosing a Water Source Heat Pump by VERSOL GROUP.

In your interest and to maintain the highest level of performance and duration of your appliance, we recommend that you follow the instructions contained in this booklet and have regular maintenance performed by qualified personnel.

We would like to remind you that failure to follow the instructions contained in this booklet may invalidate the guarantee

In order to install and use this product correctly, please read this manual carefully before installation and use, also please keep this manual well, for future reference. Thank you for your cooperation!

This unit should have maintenance regularly. The regular maintenance and cleaning will help the product stability, security, and long-term operation. Clean the dust and dirt inside the unit will also help to improve unit heat transfer efficiency, save the energy for you.

If the unit shut down in long time due to some factors, please be sure to drain off the water in pipeline, to prevent rust or as the low temperature in winter may cause the pipe cracking and system running problem again.

With the constant progress of science and technology, product has constant update and optimization; please pay attention to the latest product information.





CONTENTS

Notes	PAGE-04
Characteristics and Parameters	PAGE-06
Installing Instruction	PAGE-07
Controller Instruction	PAGE-17
Maintenance	PAGE-23
Warranty services	PAGE-25

NOTES

- 1.1. Dear User: Before installation and use this of this product, please read this manual in detail, to avoid the problem of equipment damage, operator injury and property damage, etc.
- 1.2. If you have any questions about technology when you read the manual, please inquire the local agent or our company as soon as possible.

 **Warning** Means improper handling will cause serious injury or death.

 **Note** Means improper handling will cause injuries or property damage.

 **Remind** Means make further remind and interpretation to the contents stated

Warning

- Please entrust professional installation, the installation personnel must have the relevant professional knowledge. Prohibited to install it yourself if you are not professional, otherwise, may cause leakage, electric shock, fire and other accidents.
- When the units need to move, repair or reinstall, please entrust dealer or professionals, prohibited to do maintenance or installation yourself if you are not professional, otherwise, can lead to leakage, electric shock, fire and other accidents.
- The unit can't install near the flammable (paint, coating, gasoline, chemical reagent, etc.), in order to prevent fire or explosion.
- Non-professional personnel can not adjust the internal switches, valves, controllers, etc.
- If unfortunately have a fire, the main power supply should be immediately shut down and take the corresponding correct measures to put down the fire.
- Please use the specified capacity of the fuse or overload protector, do not use the iron wire, copper wire instead, otherwise will lead to serious damage or fire to the unit.
- When customers purchase spare parts, choose the specified products of our company, otherwise may cause leakage, electric shock, fire and other accidents.
- During the electrical installation shall comply with the relevant provisions of the state, be sure to consult the electrical wiring diagram.
- Heat pump unit must be reliable grounding, forbid to operate the unit without grounding, it is strictly prohibited to connect ground wire on the zero line or water pipe.
- It is forbidden to put fingers, clubs in heat pump units, don't touch the fan blades to avoid an accident (Children must avoid by all means).



Note

- Confirm whether installed leakage protection switch, must be installed leakage protection switch, otherwise may cause electric shock.
- Correct connection cable. If the cable connection error may damage the electrical components, do not touch the refrigerant exhaust pipe parts with the hand, to prevent burns.
- Do regular maintenance of the unit according to the instruction manual, to ensure the unit running in good condition.
- If the refrigerant leakage, should immediately cut off all the unit's power supply.
- When the fuse fusing repeatedly or leakage protection switch frequently open, should immediately stop running, cut off the power switch manually, and contact the dealer or customer service.
- When choosing to install the heat pump unit, please check whether the corresponding power supply capacity meets the requirements of this unit's power, see details on the nameplate or installation instruction.
- If the unit or water tank is mounted on the roof etc., be sure to take measures against lightning.

CHARACTERISTICS AND PARAMETER

2.1. Unit features:

◆ System Integration

Corrosion-resistant & anti-blocking heat exchanger special for water source heat pump, professional compressor, ensure the unit stable operation under changes of water quality and temperature. Meanwhile, effectively extend the unit lifetime.

◆ Safety Integration

Unit has multiple protection features: anti-freezing protection, compressor over heat protection, reverse phase protection, lack of phase protection, high and low pressure protection, overload protection, high temperature protection, water flow protection, time delay protection, etc., to provide water of the project under 100% security.

◆ Energy Saving Integration

Use the earth stored “energy” as heat source, adopt the professional heat pump technology, select special components for water source heat pump, improve the heat pump unit "heat absorption", reduce "heat island effect" , meanwhile improve the unit energy efficiency.

◆ Intelligent Integration

Use the earth stored “energy” as heat source, adopt the professional heat pump technology, select special components for water source heat pump, improve the heat pump unit "heat absorption", reduce "heat island effect" , meanwhile improve the unit energy efficiency.

2.2. Technical Data

◆ Refer to Catalogue (ET-CH).

INSTALLATION INSTRUCTIONS

3.1. Installation Notes:

- 1) Installation position of the unit is more flexible, choose well ventilated position as priority
- 2) The installation of the unit must be far away from the corrosive place.
- 3) Unit needs to have a professional installation, installation must comply with the corresponding provisions of the local government and relevant departments.
- 4) Installation's base height should be not less than 200 mm, need good unobstructed drainage in installation location.
- 5) Occasion for special installation requirements please refer to construction contractors or architects or other related professional consultation.
- 6) The unit can be installed on the ground, roof or in basement but the premises should have adequate ventilation, and meet the demand of heat exchange. Lightning protection for the whole heat pump system if the heat pump installed on the roof.
- 7) When the unit is installed on the roof, the roof must have enough strength to support the weight of the unit and related parts, the unit can be placed on the concrete basis or channel steel frame.
- 8) Don't install the unit where noise and vibration could be a nuisance.

3.2. Pipeline installation:

- 1) Piping system design and construction must conform to the national plumbing pipe design specifications and relevant standards.
- 2) When under DN50, priority to choose PPR pipe, above DN50 (including DN50) choose galvanized pipe.
- 3) The installation process must prevent dust and other debris into the piping system.
- 4) Only install water pipe after the completion of fixing the unit.
- 5) Water inlet and outlet pipe, circulation system water pipe must be packed with thermal insulation material for heat preservation.

When connecting the water input pipe and water output pipe, Must use two tongs, respectively clamped to connect the two parts, to ensure that water input pipe and water output pipe of the unit cannot be turn. As shown in the picture below:

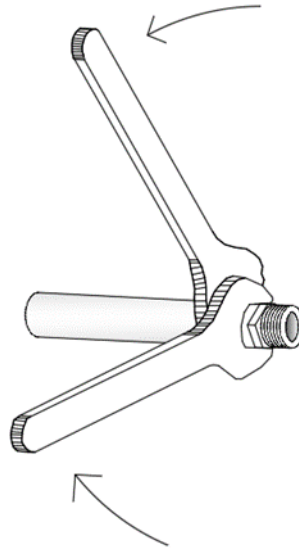

(Picture 1)

3.3. The installation position for water tank

- a. Should be easy for installation of water pipe and electrical.
- b. Should supply enough space for installation and maintenance.
- c. The support surface should be flat, must bear the max. Weight of the water tank full with water.
- d. Check for corrosive gas leaks

3.4. The installation for water level switch, overflow switch & water tank temperature probe:

The water level switch must be installed on the top interface of the water tank and fixed securely.

If cannot use threaded connection to fix the water level switch, use the lifting lug of the water level switch for hanging installation. Do not hang other position of the water level switch for avoiding damage of the water level switch.

- In order to prevent the outflow of the water in the tank, it is necessary to have the overflow outlet and install overflow switch in the water tank, its installation height must be higher than water level switch, lower than the overflow outlet.
- After the installation, please check if the water level switch (high, middle and low water level) is installed correctly, and if it can running normally.
- Water tank temperature sensor can now be contacted directly with water, therefore must set sensor blind pipe, water tank temperature sensor is installed in the blind pipe.



CALORIFIER CONNECTIONS	
A	PRIMARY RETURN
B	PRIMARY FLOW
C	TEMP GAUGE
D	AIR VENT
E	SECONDARY FLOW
F	SAFETY VALVE
G	SECONDARY RETURN
H	COLD FEED
J	DRAIN
Z	ELECTRIC HEATER

(Picture 2)

Note

● If using other types of water level switch, install it according to the actual situation of the water level switch.

3.5. Pipeline connection:



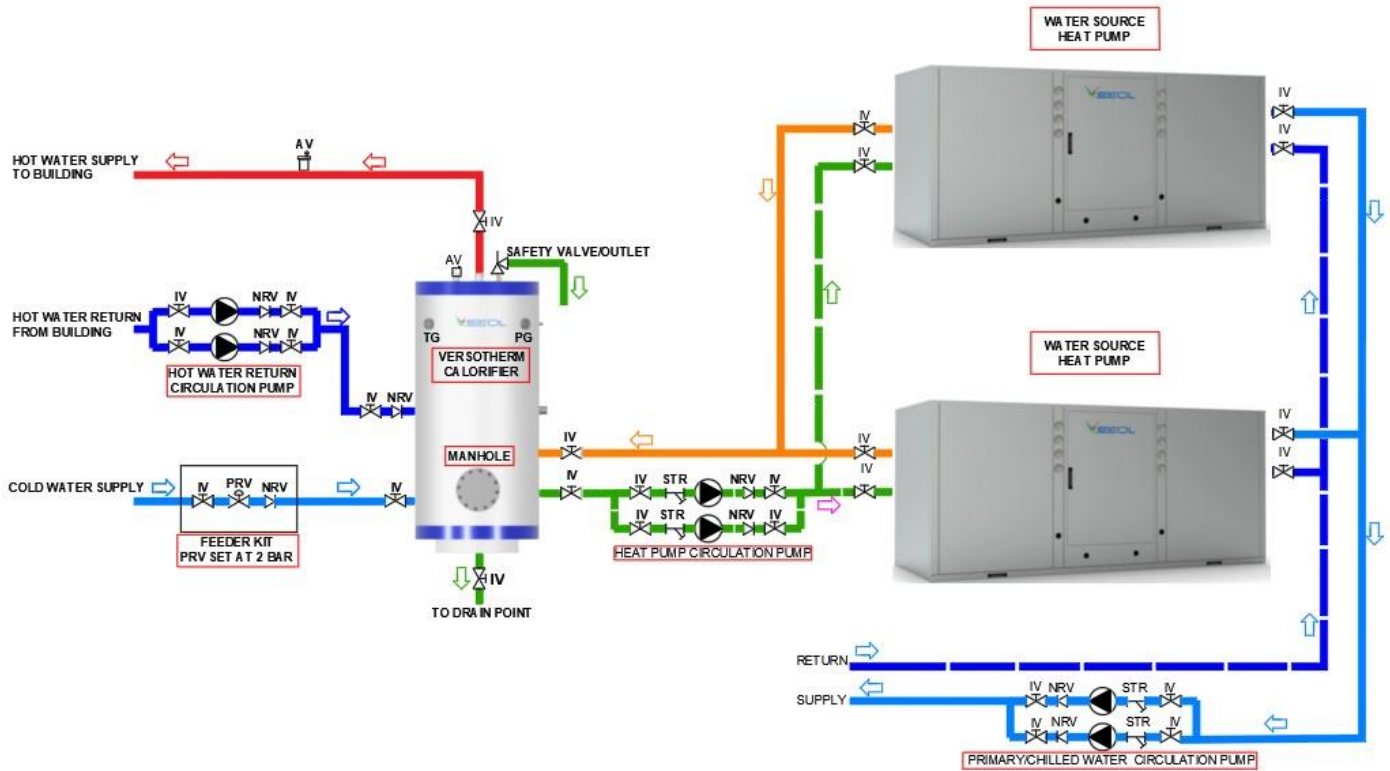













Commercial use circulation type series products pipe connection refers to (Picture 3):



(Picture 3)

Table 2 Symbol Legend

VALVES & PIPEWORK FITTINGS

SYMBOL	NAME	SYMBOL	NAME
	ISOLATING VALVE		PRESSURE GAUGE
	NON-RETURN VALVE		TEMPERATURE GAUGE
	RELIEF VALVE		TEMPERATURE SENSOR
	TWO PORT VALVE		FLEXIBLE CONNECTION
	THREE PORT VALVE		PUMP
	SAFETY VALVE		AUTOMATIC AIR VALVE
	ANGLED SAFETY VALVE		DRAIN COCK
	SOLENOID VALVE		STRAINER

3.6. Installation & selection of water pump:

3.6.1 The design & installation of the water booster pump:

- 1) The design of the system pressure is 0.20 MPa, work pressure range 0.05-0.35 MPa.
- 2) If the water inlet shall be connected to the tap water pipe network, must be connected to the main pipe of tap water.

3) When water pressure ≥ 0.40 MPa, must install pressure reducing valve, adjust the water pressure of the unit water inlet to 0.20 MPa;

4) When water pressure < 0.20 MPa, must install automatic constant pressure device.

5) Rated flow design for automatic constant pressure device:

Rated flow = unit rated water producing quantity \times quantity of units

3.6.2 The design and installation of the hot water circulating pump:

6) Circulating water pump rated head of delivery:

The most unfavorable circulation pipeline $(L1 + L2 + L3 + \dots + Ln) \times$ resistance coefficient + pipeline total local resistance + unit resistance

7) Rated flow of circulating water pump: Single unit cycle heating rated flow \times quantity of units



Note

- When unit cycle heating, specific heat exchange side water flow please refer to performances table.



Note

- Hot water circulating pump must use hot water pump; the high temperature bearing capacity of the circulating water pump can not be lower than 80°C.

3.7. Water quality requirements

Geothermic series products only used for domestic hot water, the hot water be heated must comply the requirements as below table 3:

Table 1 Water quality requirement

Project			Reference value	Tendency	
				Corrosion	Scaling
Basic items	PH Value pH(25°C)		6.5~8.0	0	0
	Electrical conductivity(25°C)	μS/cm	<800	0	0
	Chloridion Cl ⁻	mg(Cl ⁻)/L	<200	0	
	Sulfate ion SO ²⁻	mg(SO ²⁻)/L	<200	0	
	Acid consumption (pH=4.8)	mg(CaCO ₃)/L	<100		0
	Full hardness	mg(CaCO ₃)/L	<200		0
Other items	Ferrum Fe	mg(Fe)/L	<1.0	0	0
	Sulfur ions S ²⁻	mg(S ²⁻)/L	not allowed	0	
	Ammonium ion NH ⁺	mg(NH ⁺)/L	<1.0	0	
	Silicon chloride SiO ₂	mg(SiO ₂)/L	<50		0

Note: 0 means corrosion or scaling tendency of relevant factors



Note

- When the water quality can not reach the requirements, Equip corresponding water treatment equipment according to the water quality situation.

3.8. Electrical installation:

Electrical installation considerations:

- 1) The unit should use independent power supply, and power supply circuit must be earthed.
- 2) Should have protection measures against electric leakage and short circuit, according to the relevant state regulations on electrical equipment standards.
- 3) When parallel wiring of high voltage and low voltage, please wire into a separate wire tube, to keep a proper distance.

4) After all wiring completed, please check carefully an check for faults before connecting to power supply.

3.9. Power wiring requirements:

Comply as per Standard.

3.10. Connect to power supply:

Power wiring refer to the below connecting picture (4):

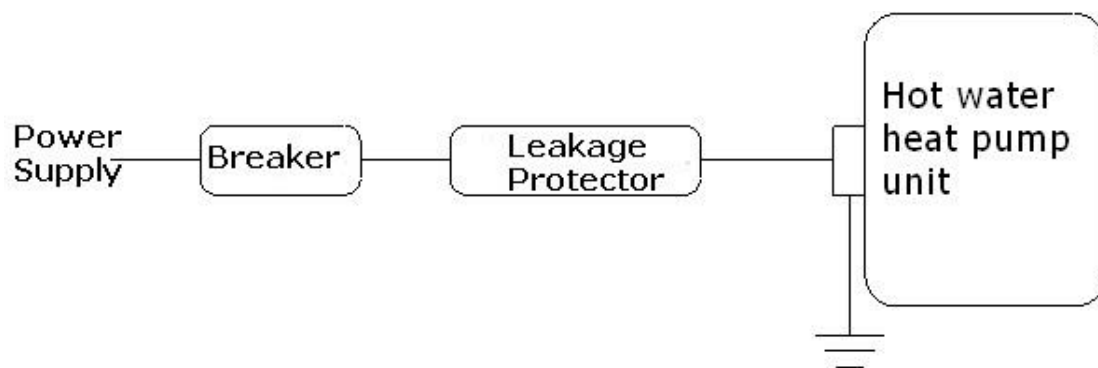

(Picture 4)

Note

- Choose insulated copper core wire for electrical wiring.
- The circuit breaker shall be selected with overload, short circuit protection function, when selected circuit breaker is with three kinds of protection functions of overload, short circuit & leakage, leakage protector can not be installed.

3.11. Wire connecting

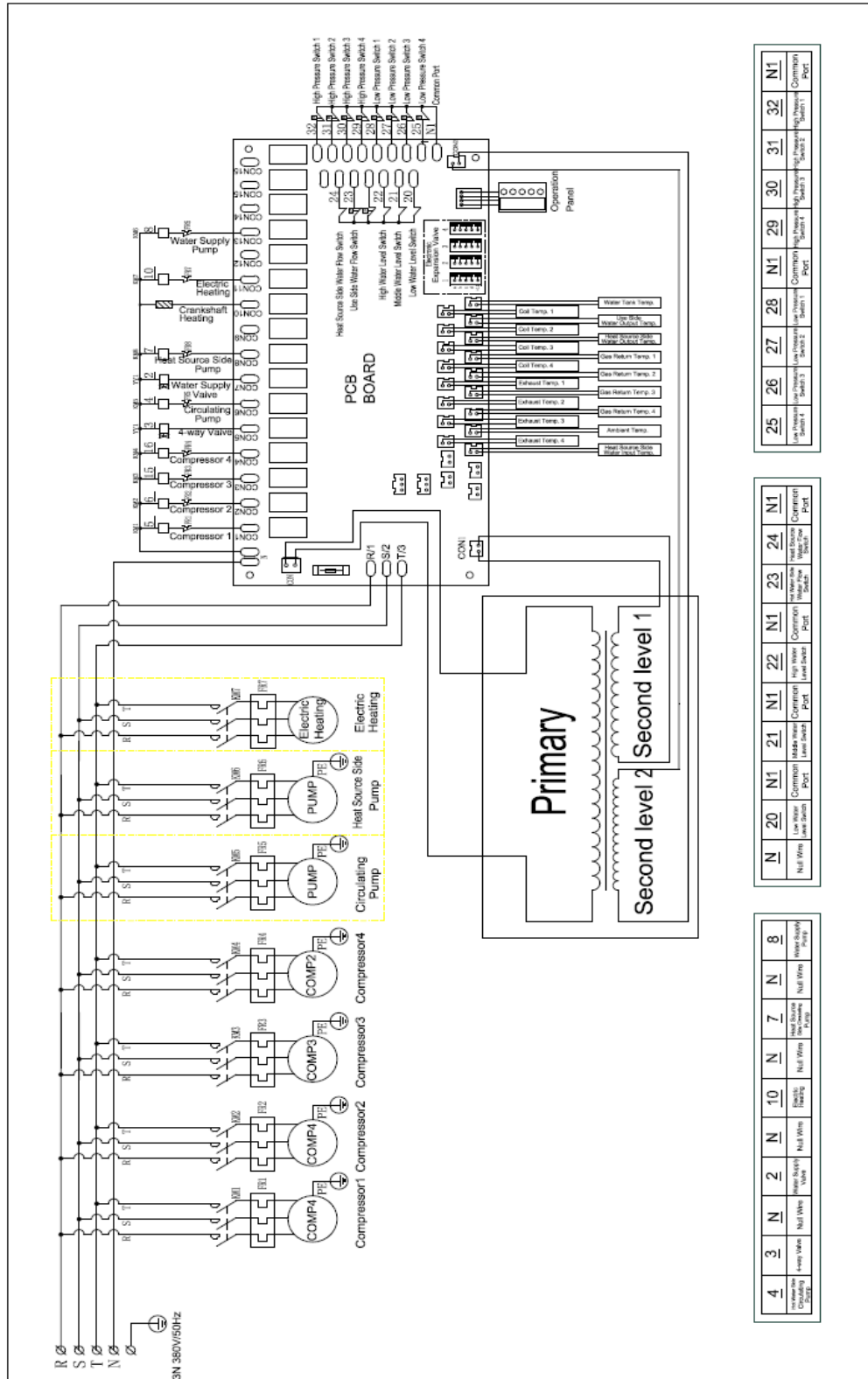



Note

- For single phase power supply, if the null wire & fire wire of the power supply
- connect wrongly, the compressor does not start, meanwhile the heat pump controller shows the failure code. change the order of null wire and fire wire, power on again, until failure on the controller be solved, the compressor will start normally.
 - For three phases power supply, note for the connecting order of R,S,T. if connecting wrongly, the compressor does not start. the failure and solve solution as same as above.



Note

- As the products are constantly updating and optimizing, if the wiring diagram and stickers of the unit are different with the instruction manual, please refer to the unit wiring diagram and stickers as priority.



CONTROLLER INSTRUCTION

Controller main function

1, heating operation

2, can display the tank temperature and set temperature, with query function (can query coil temperature, ambient temperature, exhaust temperature, etc.)

3, automatically memorize various parameters when power is off, automatically resume running after incoming call

4, the clock is still running after power failure, saving the trouble of re-adjustment every time

5, the peak power function, two-stage timer switch can be realized within 24 hours

6, various parameter settings and corrections

7, electric auxiliary heating function

8, password settings

9, automatic defrost function

10, forced defrosting function

11, cooling function

12, large LCD display (full transparent LCD screen white background)

13, with perfect protection, including current transformer protection

14, fault code display query (can query compressor failure or compressor stop failure) and keyboard lock function

15, the switch machine displays the water temperature in real time.

16, three-phase power phase loss, reverse phase protection

17, straight water + circulating water mode and independent circulating water mode selection

18, electronic expansion valve automatic control

19, crankshaft heating control

20, antifreeze function

21, in the absence of a panel (or panel damage), the system can automatically identify

and automatically open the mechanism hot water

1. Control panel diagram

1.1 English panel

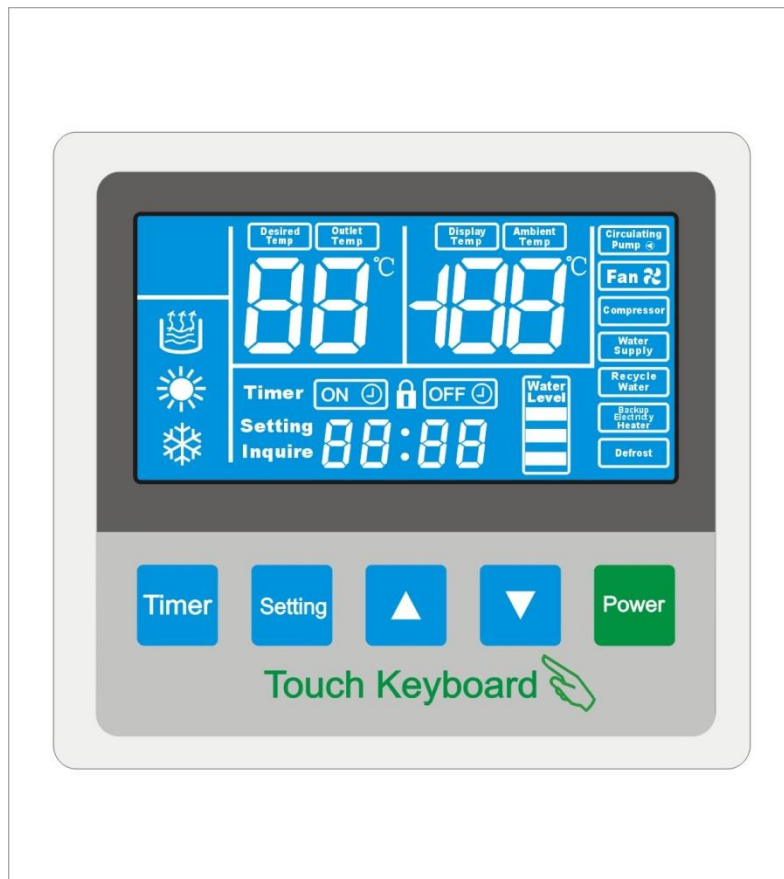

Note: The temperature displayed on the left hand side of the operation panel is the set temperature, and the temperature displayed on the right hand side is the actual temperature of the water tank.

2. Operation

When the operation panel is powered on, the buzzer will sound for a long time, and the display will show that the backlight is slightly bright. At this time, the touch button is locked, and any button is invalid.

2.1 Button unlock: Touch the “Power” button with your finger for more than about 3 seconds. When you hear the “beep” sound, remove the finger. At this time, the backlight is highlighted, the button is unlocked, and there is no lock symbol (about 60). If there is no button operation in seconds, the button will be automatically locked and the lock button symbol will be displayed.

2.2 On/Off: Touch the “Power” button with your finger. If the panel is turned on, it will be turned off. If the panel is turned off, it will be turned on.

2.3 Water tank temperature setting: Touch the “▲” button with your finger, the “Set



Temperature” symbol will start flashing and display the water tank setting temperature, then touch the “▲” button with your finger to increase the water tank setting temperature. Touch the “▼” button with your finger, the “Set Temperature” symbol will start flashing, and the temperature setting of the water tank will be displayed. Then touch the “▼” button with your finger to decrease the water tank setting temperature. Water tank temperature setting range: 20 degrees - 65 degrees (if the temperature requirements exceed 65 degrees, please inform us, you need to modify in the program).

2.4 Timing time setting: Touch the “Timer” button with your finger to enter the timing setting mode.

First adjust the timing of the first period of timing to start "hour", then touch the "Timer" button with your finger, then adjust the timing of the first period of timing to turn "minute", then touch the "Timer" button with your finger, then adjust the first The timing of the segment timing is turned off "hour", then touch the "Timer" button with your finger, then adjust the timing of the first segment of time to turn off the "minute", and then touch the "Timer" button with your finger to enter the second segment timing, second The segment timing setting is the same as above, and the setting mode is exited after all the timing time is set.

When the setting mode is exited after all the timings have been set, the timer switch icon is displayed on the panel.

Note: 1. When setting the time period, if only one time period is needed, after setting the first time period according to the above steps, the power-on and power-off time of the second time period must be set the same. The time period is valid.

2. If only the first period of timing is set when the timing is set, and the second section is not set, the timing setting function will be automatically exited after about 8 seconds.

3. The first and second segments in the timing function key are the timed power-on function keys. The third and fourth-stage timing functions are used for the water supply pump timing water supply function. If there is no water supply pump function, this function is invalid. However, when setting the timed start, all the four-segment timing functions must be pressed. The numbers in the third and fourth paragraphs are not required.

2.4.1 Timing Cancellation: Touch the “Timer” button with your finger for more than about 3 seconds. When you hear the “beep” sound and then remove your finger, the timing will be canceled.

2.5 Clock setting: Touch the “Timer” button with your finger for more than 8 seconds. When you hear the “beep” sound, remove your finger and enter the clock setting mode. First adjust the "hour" of the clock, then touch the "Timer" button with your finger, then adjust the "minute" of the clock, and then touch the "Timer" button with your finger, then the setting is completed and the setting mode is exited.

Note: The clock can only be set if no timing is set.

2.6 Forced Defrost: When the system is turned on and the compressor is started, touch the “▼” button with your finger for more than 8 seconds. When you hear the “beep” and then remove your finger, the system enters the defrost. Coil temperature or defrosting time reached required value then exit defrosting.

2.7 Cooling mode: When the system is turned on, in the hot water mode, touch the “▲” button with your finger for more than 8 seconds. When you hear the “beep” sound, remove your finger and enter the cooling mode, water temperature adjustment range: 5°C-30°C. When the “▲” button is touched with the finger in the cooling mode and exceeds about 8 seconds, it enters the heating mode.

Parameter setting and query (deputy table 1)

A: Function query:

In the state of power on, touch the “Setting” button with your finger, the query code can be increased from A1 to A9. If it is a single system model, touch the “Setting” button with your finger to exit the query mode. If it is a four systems model, then Touch the “Setting” button with your finger, the query code can be increased from b1 to D9, and then touch the “Setting” button with your finger to exit the query mode. The corresponding representations are as follows:

Query code	Representative meaning	Query code	Representative meaning	Query code	Representative meaning	Query code	Representative meaning
A1	Coil temperature 1	b1	Coil temperature 2	C1	Coil temperature 3	D1	Coil temperature 4
A2	Gas return temperature 1	b2	Gas return temperature 2	C2	Gas return temperature 3	D2	Gas return temperature 4
A3	Exhaust temperature 1	b3	Exhaust temperature 2	C3	Exhaust temperature 3	D3	Exhaust temperature 4
A4	Ambient temperature	b4	Ambient temperature	C4	Ambient temperature	D4	Ambient temperature
A5	Water outlet temperature 1	b5	Water outlet temperature 2	C5	Water outlet temperature 3	D5	Water outlet temperature 4
A6	Back water temperature	b6	Back water temperature	C6	Back water temperature	D6	Back water temperature
A7	00	b7	00	C7	00	D7	00
A8	Compressor current 1	b8	Compressor current 2	C8	Compressor current 3	D8	Compressor current 4
A9	Expansion valve opening	b9	Expansion valve opening	C9	Expansion valve opening	D9	Expansion valve opening
ER	Fault code query	ER	Fault code query	ER	Fault code query	ER	Fault code query

Note: 1. If you use our thermostat, you can check the A7 water flow through the panel. If not, it is displayed as 00.

2. If you want to query the historical fault condition, after querying the fault code to the ER, press the up “▲” key to query ER1---ER6, that is, 6 historical fault conditions.

B: Function setting:

In the power on state, touch the “Setting” button with your finger for more than 3 seconds.

When you hear the “beep” sound, remove your finger and enter the parameter setting mode. After setting the parameters, touch the “Setting” button with your finger. Go to the setting of the next parameter until all parameters are set and exit the setting mode. The corresponding representations are as follows:

Setting code	Parameters name	Adjustable range	Initial value
/ / /	Water tank temperature setting	20°C–65°C	55°C
L1	Water tank temperature and display temperature deviation setting	0°C–15°C	0°C
L2	Compressor start and set temperature deviation setting	3°C–18°C	5°C
L3	Water output temperature setting	35°C–99°C	55°C
L4	Water tank temperature upper limit	30°C–99°C	65°C
L5	The ambient temperature allows electric heating to turn on	0°C–35°C	0 (0 is no electric heating)
L6	Back water temperature	30°C–65°C	45°C
L7	Allowable water refilling temperature	20°C–60°C	20°C(20°C is no water refilling)
L8	Compressor current	0-48A	0 (0 is no testing)
h1	Spare		
h2	Spare		
h3	Spare		
h4	Anti-freezing protection	1°C–40°C	3°C
p1	Electronic expansion valve adjustment cycle	20-180	30 secs
p2	Superheat degrees	-8–15	0
p3	Allow the electronic expansion valve to open to max. Degrees when the exhaust temperature is reached	70°C–135°C	90°C
p4	Opening degree of electronic expansion valve during defrosting	6-55 degrees	50
p5	Expansion valve minimum opening	6-30 degrees	15
P6	Superheat degrees compensation	0-12°C	1°C

C: Fault code display, alarm:

Fault code table

Code	Four systems
1	Wrong phase
2	Missing phase
3	Flow switch
5	High pressure switch 1
6	Low pressure switch 1
7	High pressure switch 2
8	Low pressure switch 2
9	communication
11	Limited time
12	Exhaust temperature 1 is high
13	Exhaust temperature 2 is high
15	Water tank temperature transmission
16	Coil temperature 1 sensor
17	Coil temperature 2 sensor
18	Exhaust temperature 1 sensor
19	Exhaust temperature 2 sensor
21	External ambient temperature sensor
22	Backwater temperature sensor
23	Inlet water temperature sensor
25	Water level switch
26	Inlet water temperature is too high
27	Outlet water temperature sensor 1
28	Outlet water temperature sensor 2
29	Return air temperature sensor 1
30	Return air temperature sensor 2
31	Water source side water flow switch
32	Water source side water temperature is low
33	Low circulating water temperature
35	Compressor 1 over-current
36	Compressor 2 over-current
37	Thermostat 1 without water flow
38	Thermostat 2 without water flow



39	High cooling water temperature
40	Large difference in water temperature between source water
41	Circulating water temperature difference
63	Water flow switch 2
65	High pressure switch 3
66	Low pressure switch 3
67	High pressure switch 4
68	Low pressure switch 4
72	Exhaust temperature 3 is high
73	Exhaust temperature 4 is high
76	Coil temperature 3 sensor
77	Coil temperature 4 sensor
78	Exhaust temperature 3 sensor
79	Exhaust temperature 4 sensor
89	Return gas temperature 3 sensor
90	Return gas temperature 4 sensor
95	Compressor 3 over-current
96	Compressor 4 over-current



MAINTENANCE

The heat pump is a more automatic equipment needing inspection regularly. If the maintenance is long-term and effective, the operation reliability and the service life will be greatly increased.

Maintenance must be operated by qualified persons.

1. Clean the water filter regularly to ensure the clean water in system and avoid the damage caused by blocking.
2. When use and maintain the heat pump unit, please noted that all safety protection and parameters are pre-set by factory, do not change at random.
3. Always check whether the power unit and electrical system cable is solid, and there are no abnormal movements between electrical components. If so, carry out timely maintenance and replacement.
4. Check if the filling water valve of water system, safety valve of water tank, liquid level controller and safety valve works normal, in order to avoid air into the system led to the water quantity decrease, thus affecting the heating capacity and the reliability of unit.
5. Check whether the water pump and water valve are working properly, check whether the water pipeline or pipe fittings have the problem of leakage.
6. Keep units in clean, dry and well ventilated environment, also regularly clean (1-2 months) the fin evaporator with clean water, to keep good heat absorption, turn the power off when cleaning.
7. Checking whether the components of units working properly, check whether the unit pipe connectors and air valves are with oil, make sure no leakage.
8. To avoid blocking of the fan outlet, around the unit should be kept clean and dry, well ventilated.
9. Drain the water, cut off the power and put a protective cover, if the downtime is long. A comprehensive checking is necessary before using the unit again.
10. Please contact with the local special maintenance department of our company for the repairs if you can not solve failures.
11. About the condenser cleaning, our company recommend adopt 50°C~60°C, the concentration of 15% thermal phosphoric acid solution to clean the condenser, start the unit with circulation pump to clean 3 hours, finally rinse with water for 3 times. (when installation the pipe, please reversed tee interface, using a plug seal interface), in case the pipe connection. Using corrosive cleaning material to clean the condenser is banned.

12.The tank needs to be in use after a period of time (generally for two months, depending on the local water quality).

 **Note**

- **Clean the heat source side heat exchanger by professional personnel.**
- **When using cleaner,should according to dirt deposition to adjust the concentration of cleaner,cleaning place and cleaning time and so on.**
- **After cleaning,need to deal with waste liquid.**
- **After using cleaner,use clear water to clean water pipe and heat exchanger,do water treatment to prevent water system corrosion or the dirt water readsorption**
- **Because some cleaner has corrosion damage to skin,eyes etc,so the protection device must be used in the cleaning process(gloves,mask and gobe etc.)**



WARRANTY

1. The free warranty of our air source heat pump is 24 months, starts from the date of purchase. The after-sale service department of our company will provide consumers free services due to the failure of the product quality under warranty.

2. Warranty certificate:

The heat pump units are free to repair during the warranty period, if the users have the purchase invoice and products warranty card, and need to the product number is same as the warranty card number.

If not, the units are regarded as products surpassing the warranty period.

These products are not enjoy free warranty service, but the company can provide paid services for users.

3. The damages caused below are not in the free warranty coverage, but our company could provide paid service.

a. Damage due to the consumer installing, dismantling and repairing.

b. Damage due to transportation and maintenance by consumer themselves, or not Using referring to the manual.

c. Failure due to power supply not meet requirements, or due to natural disasters.

d. Failure duo to the dirty of the outdoor exchanger and the water system, also the irregular clearing the exchanger and filter.

e. Not properly equipping filter for the refilling cold water pipe and water inlet pipe.

f. Equipment failure caused by forced running for large water production seriously Exceeds the heat pump capacity.

g. The warranty card number of the product maintained does not match the product number.

h. Warranty card altered with an eraser or revised.

i. No warranty card and purchase invoices.

j. Over warranty period products.

4. Warranty Process

a. After installation the unit, debugging qualified, please fill in(warranty card),and submit sheet A to the installation company.

b. Warranty card sheet B is the necessary proof of warranty for free warranty service, Please keep it well.

c. Please fill in the content neatly which is needed on warranty card, in order that our Company can provide service for you.

GENERAL SCHEMATIC AND BASIC DESCRIPTION

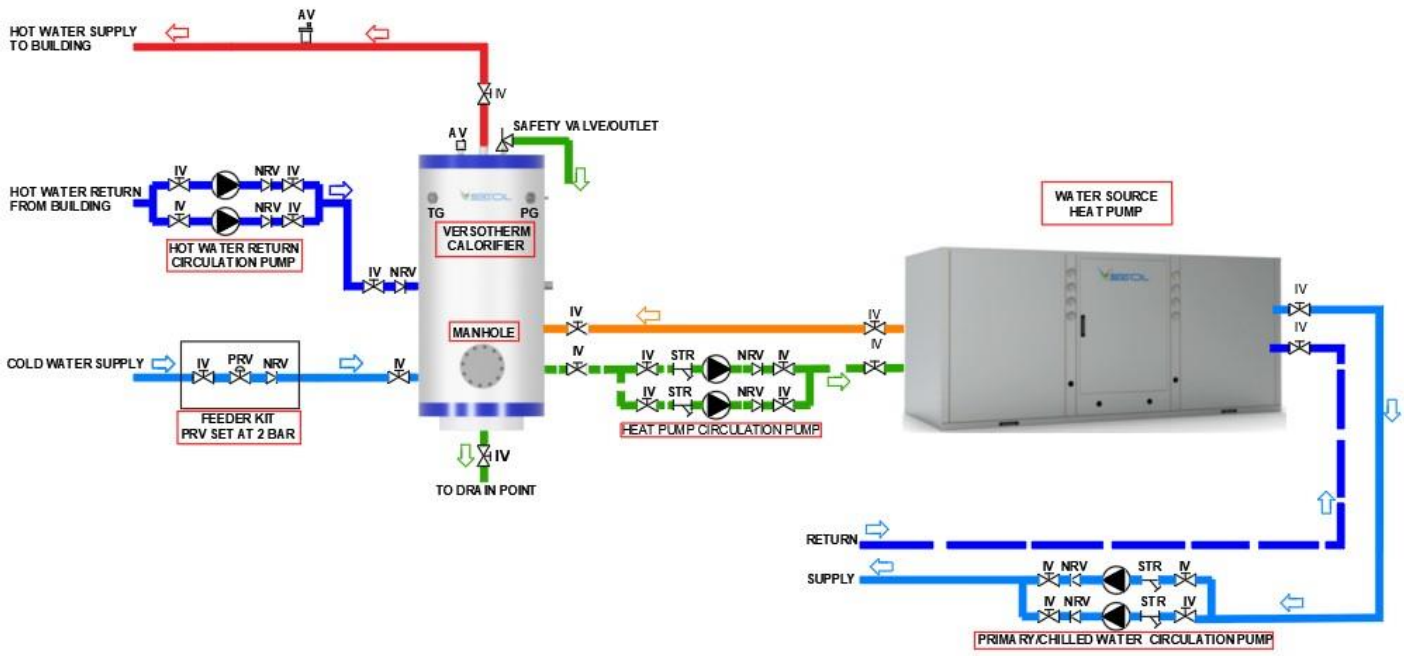



Cold water supply will enter and fill the storage Calorifier where the water is stored and getting heated up (by Water Source Heat Pump).

From storage Calorifier water will travel to the water source heat pump primary side through circulation pump, heated up water from water source heat pump primary side will go back to the storage Calorifier thus creating a continuous loop up until hot water temperature in the storage Calorifier is reach as per required / set temperature.

Whenever the water temperature in the storage Calorifier is less than 5°C of set temperature (example 60°C), water source heat pump and heat pump circulation pump will turn on and heat up the water in the storage Calorifier to the required/set temperature. Water source heat pump secondary side and secondary circulation pump will turn on same time primary side is working (water source heat pump secondary side main purpose is for cooling application).

Heat Pump circulation pump and secondary circulation pump will shift operation based on timer, which can be set at from 15 min to 8 hr.

BASIC WATER SOURCE OPERATION MODE		
If storage calorifier temperature is $\leq 55^{\circ}\text{C}$		Heat Pump = ON (Duty) Heat Pump Circulation Pump-1 ON (Duty) Secondary Circulation Pump-1 ON (Duty)
If storage calorifier temperature is = 60°C		Heat Pump = OFF Heat Pump Circulation Pump-1 = OFF Secondary Circulation Pump-1 OFF

NOTE: Heat Pump hot water heating item quantity, system description, control philosophy, sequence of operation and control logic may vary.



Versol Poland | Versol Italy | Versol UK | Versol USA | Versol Middle East | Versol India

