



INSTRUCTIONS BOOKLET FOR INSTALLATION, USE AND MAINTENANCE

POLESTAR DC INVERTER SPLIT TYPE

Inverter Air Source Heat Pump

Split system

Product Data & Installation Manual



Indoor Unit

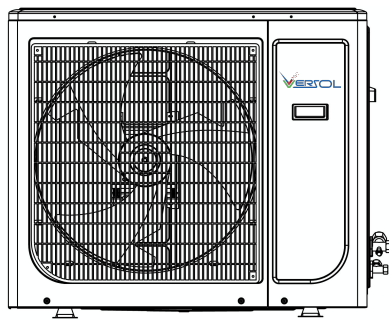

RF8I/bdm

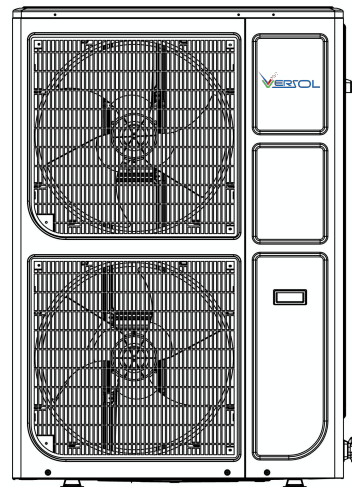

**RF12I/bdm
RF13I/bdm
HF20I/bdm**

TABLE OF CONTENT

INSTRUCTIONS	
1 General Information	1
Model identification	1
Items inside product box	1
Tools needed to install these products.....	3
SAFETY	
PRECAUTIONS	3
Warning	4
Caution	5
Material needed.....	6
OVERVIEW OF THE UNIT	8
Outdoor unit (External & Internal): RF8l/bdm	8-12
Outdoor unit (External & Internal): RF12l/bdm & RF13l/bdm & HF20l/bdm	14
Wiring Diagram	8
Field Wiring	22
INSTALLATION OF THE INDOOR UNIT	23
Installing.....	
cardboard.....	24
Water pipe-work	25
INSTALLATION OF THE OUTDOOR UNIT	27
Precautions for selecting the location.....	27
Installation space.....	27
Mounting the outdoor unit	28
Refrigerant piping work	31
Purging air and checking gas leakage	32
Charging refrigerant	34
Pre-operation Checks	35
Checks before initial start-up	35



READ THIS MANUAL CAREFULLY BEFORE STARTING THE INSTALLATION OF THIS PRODUCT. DO NOT THROW IT AWAY.

KEEP IT IN YOUR FILES FOR FUTURE REFERENCE.



BEFORE OPERATING THE UNIT, MAKE SURE THE INSTALLATION HAS BEEN CARRIED OUT CORRECTLY BY A PROFESSIONAL DEALER. IF YOU FEEL UNSURE ABOUT OPERATION, CONTACT YOUR DEALER FOR ADVICE AND INFORMATION.

INTRODUCTION

This manual

This manual includes the necessary information about the unit. Please read this manual carefully before you install the product.

General information

The split system consists out of two parts: the Indoor unit and the Outdoor unit. They are connected through refrigerant pipes. The indoor unit is the indoor part of the reversible air to water heat pump. These units are designed for all mounted indoor installations and used for heating and hot water applications. The unit can be combined with fan coil units, under floor heating, low temperature radiators, and domestic hot water tanks.

The system is delivered with an integrated backup heater for additional heating capacity during cold outdoor temperatures. The backup heater also serves as a backup in case of malfunction of the outdoor unit.

Domestic hot water tank option

An optional domestic hot water tank with integrated electrical booster heater can be connected to the indoor unit. The domestic hot water tank is available in different sizes.

Items inside product boxes

Before starting installation, please make sure that all parts are found inside the product boxes

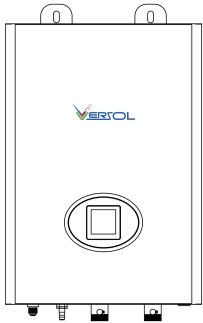
Indoor Unit Box		
Item	Image	Quantity
Indoor unit		1

Installation Manual

Inverter Air Source Heat Pump
Split system

Product Data & Installation Manual



Indoor Unit

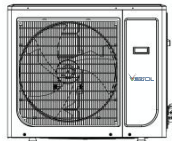

RF8I/bdm

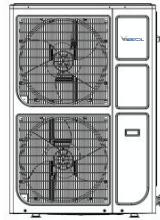

RF12I/bdm
RF13I/bdm
HF20I/bdm

1

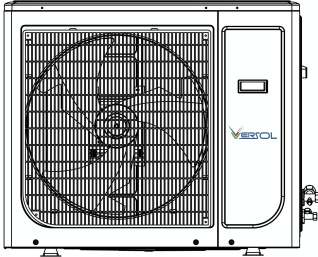
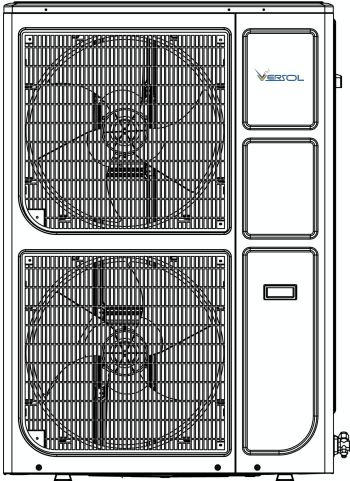
Outdoor Unit Box		
Item	Image	Quantity
Outdoor unit (RF8I/bdm)		1
Outdoor unit (RF12I/bdm & RF13I/bdm& HF20I/bdm)		1

The Tools needed for the installation of this Heat Pump

1. Hammer Drill
2. Spirit Level
3. Pipe Bending equipment for refrigeration pipe
4. Pipe bending equipment for water pipe
5. Brazing torch
6. Flaring tool
7. Tape measure
8. Torque spanners
9. Pipe cutters
10. Socket set with metric sockets
11. Screwdriver
12. Wire strippers
13. Vacuum pump
14. Pressure gauge
15. Electronic scale
16. Adjustable spanner
17. Protective equipment such as gloves and glasses

SAFETY INSTRUCTIONS

To prevent injury to the user, other people, or property damage, the following instructions must be followed. Incorrect operation due to ignoring these instructions may cause harm or damage.

Install the unit only when it complies with local regulations, by-laws and standards. Check the main voltage and frequency. This unit is only suitable for earthed sockets. An isolation switch is required for both indoor and outdoor units.

The following safety precautions should always be taken into account:

- Be sure to read the following WARNING before installing the unit.
- Be sure to observe the cautions specified here as they include important items related to safety.
- After reading these instructions, be sure to keep it together with the manual in a handy place for future reference.

WARNING

- **Ensure the indoor and outdoor units are securely installed.**
If the units are insufficiently secured or installed, the unit could fall causing injury. The minimum support weight of 20g/mm² of the installation is required. When installing the unit in an enclosed area or a confined space please consider the room measurements and sufficient ventilation to prevent the asphyxia caused by the leakage of refrigerant.
- **Use the specified electrical wires and attach the wires firmly to the terminal board (connection in such a way that the stress of the wires is not applied to the sections).**
Incorrect connection and fixing could cause a fire.
- **Be sure to use the correct or specified materials for the installation work.**
The use of defective parts / materials could cause an injury due to possible fire, electric shocks, the unit falling etc.
- **Perform the installation securely and please refer to the installation instructions.**
Incorrect installation could cause an injury due to possible fire, electric shocks, the unit falling, leakage of water etc.
- **Perform electrical work according to the installation manual and be sure to use a dedicated section.**
If the capacity of the power circuit is insufficient or there is an incomplete electrical circuit, it could result in a fire or an electric shock.
- **The unit must always have an earthed connection.**
If the power supply is not earthed, you may not connect the unit.
- **Do not attempt move/repair the unit yourself if you are not a LCP installer.**
Improper movement or repair on the unit could lead to water leakage, electrical shock, injury or fire. Have any repairs and/or maintenance only carried out by a recognized service engineer.
- **Do not plug or unplug the power supply during operation**
There is a risk of fire or an electric shock
- **Do not touch/operate the unit with wet hands**
There is a risk of fire or an electric shock
- **Do not place a heater or other appliances near the power cable**
There is a risk of fire or an electric shock
- **Be cautious that water could not be poured to the product directly, do not allow water to run into electric parts**

There is a risk of fire or an electric shock

 IF THE PRODUCT IS NOT USED FOR LONG PERIODS OF TIME, WE STRONGLY RECOMMEND NOT TO SWITCH 'OFF' THE POWER SUPPLY TO THE PRODUCT.

 IF THE POWER IS NOT SUPPLIED, SOME OF THE PRODUCT-PROTECTING ACTIONS (SUCH AS WATER PUMP ANTI-LOCKING & CRANK CASE HEATER) WILL NOT BE OPERATIONAL

CAUTION

Do not install the unit in a place where there is a chance of flammable gas leaks.

If there is a gas leak and gas accumulates in the area surrounding the unit, it could cause an explosion.

Perform the drainage/piping work according to the installation instruction.

If there is a defect in the drainage/piping work, water could leak from the unit and household goods could get wet and be damaged.

Do not clean the unit when the power is 'on'.

Always shut 'off' the power when cleaning or servicing the unit. If not, it could cause an injury due to the high speed running fan or an electrical shock.

Do not continue to run the unit when there is something wrong or there is a strange smell.

The power supply needs to be shut 'off' to stop the unit; otherwise this may cause an electrical shock or fire.

Be cautious when unpacking and installing the product.

Sharp edges could cause injury. Especially watch the edges and the fins on the heat exchanger of the product.

Always check for gas (refrigerant) leakage after installation or repair of product.

Low refrigerant levels may cause failure of the product.

The installation of the indoor and outdoor unit must be level and secure.

To avoid vibration and or water leakage

Do not put your fingers or others into the fan, or evaporator.

The fan runs at high speed, this could cause serious injury.

In order to avoid a hazard due to inadvertent resetting of the thermal cut-out, this appliance must not be supplied through an external switching device, such as a timer, or connected to a circuit that is regularly switched on and off by the utility.

This appliance has not been designed for use by persons (including children) with reduced physical, sensorial or mental faculties or by persons without any experience or knowledge of heating systems, unless they act under the safety and supervision of a responsible person or have received prior training concerning the use of the appliance. Children should be supervised to ensure that they do not play with the appliance.

If the supply cord is damaged, it must be replaced by the manufacturer or its service agent or a similarly qualified person in order to avoid a hazard. The means for disconnection must be incorporated in the fixed wiring and have an air gap contact separation of at least 3mm in each active(phase)conductors.

Materials needed to install Split Heat Pumps

Indoor unit inlet/outlet water pipe fittings use 3/4" male screw connector.

2 Way Valve when requiring Zone Heating - NB each Zone requires a 2 way valve

Outdoor unit power supply line (separate power supply): 9KW with $\geq 4 \text{ mm}^2$ three-core insulated wire;
15KW / 18KW /20KW $\geq 6 \text{ mm}^2$ three-core insulated wire.

Indoor unit power supply line(separate power supply): with $\geq 4 \text{ mm}^2$ three-core insulated wire, field wiring need isolation device.

Low voltage inter connecting cable 0.75mm shielded twisted pair.

NB all controls cable must be installed 300mm away from mains cables

Refrigerant pipe connections

RF8I/bdm Liquid = 3/8 Gas =5/8

RF12I/bdm Liquid = 3/8 Gas =5/8

RF13I/bdm Liquid = 3/8 Gas =5/8

HF20I/bdm Liquid = 3/8 Gas =5/8

The required insulation for the field pipe installation is Class '0'.

Heating operation range

Condition		Outdoor		Indoor
		Dry bulb	Wet Bulb	Inlet
Heating	Max.	43	/	50
	Min.	-30	/	10

Cycle diagram

RF8I/bdm / RF12I/bdm/ RF13I/bdm /HF20I/bdm

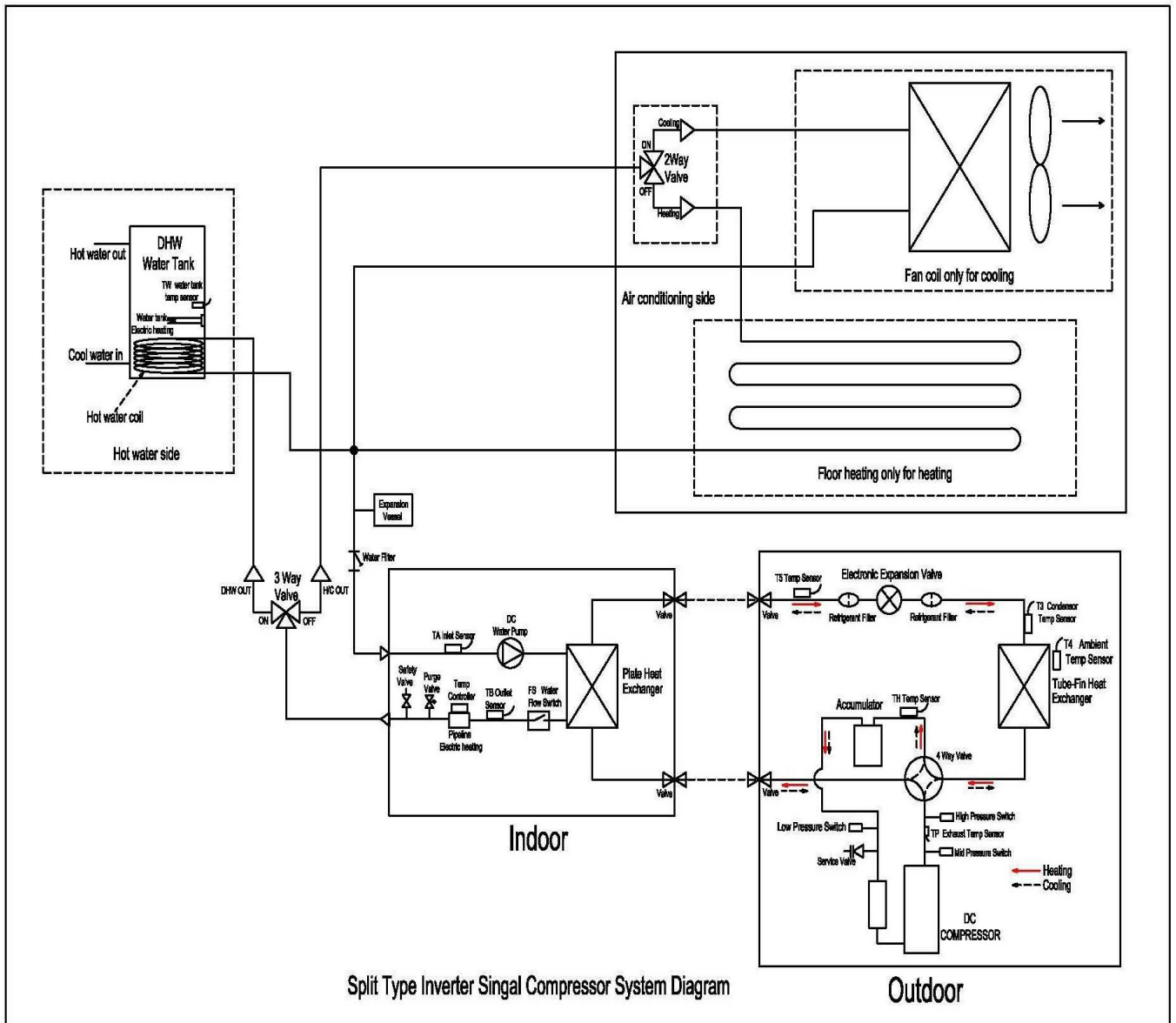

OVERVIEW OF THE UNIT

Indoor unit RF8I/bdm/ RF12I/bdm/ RF13I/bdm/ HF20I/bdm models (External)

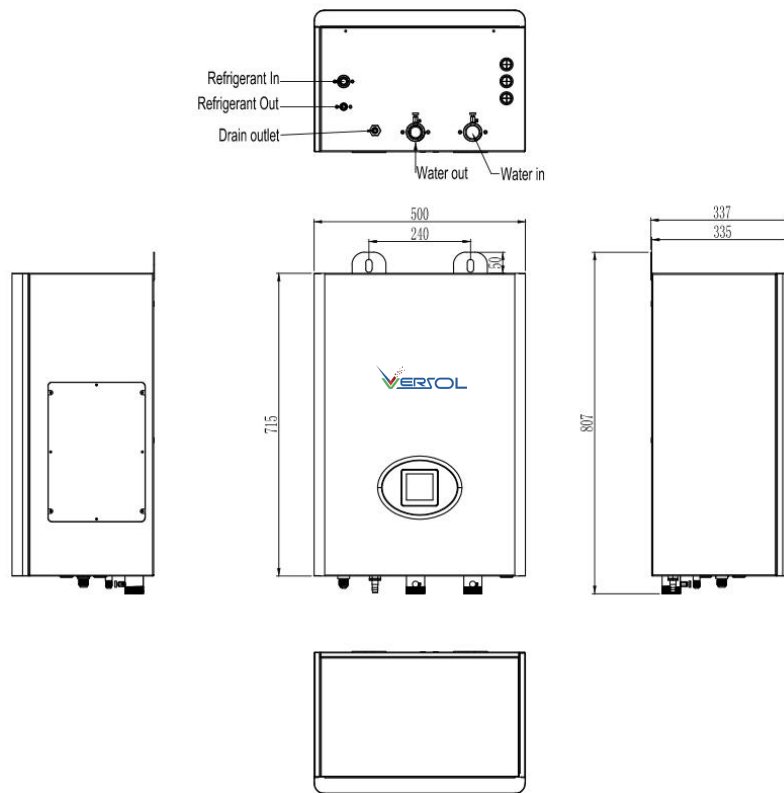

Indoor unit RF8I/bdm/ RF12I/bdm/ RF13I/bdm/ HF20I/bdm models (Internal)

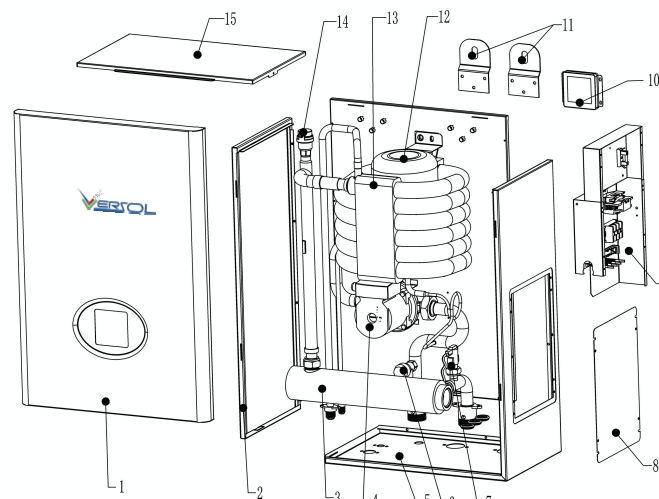

NO.	Name	NO.	Name	NO.	Name
1	Front panel	6	Safety valve	11	hangs plate
2	Left side panel	7	Flow switch	12	Expansion tank
3	Electric heater assembly	8	Electronic controller box cover	13	Tube in tube heat exchanger
4	Water Pump	9	Electronic controller assembly	14	Exhaust valve
5	Right side panel	10	Wired Controller	15	Top cover

Outdoor unit (External): RF8I/bdm

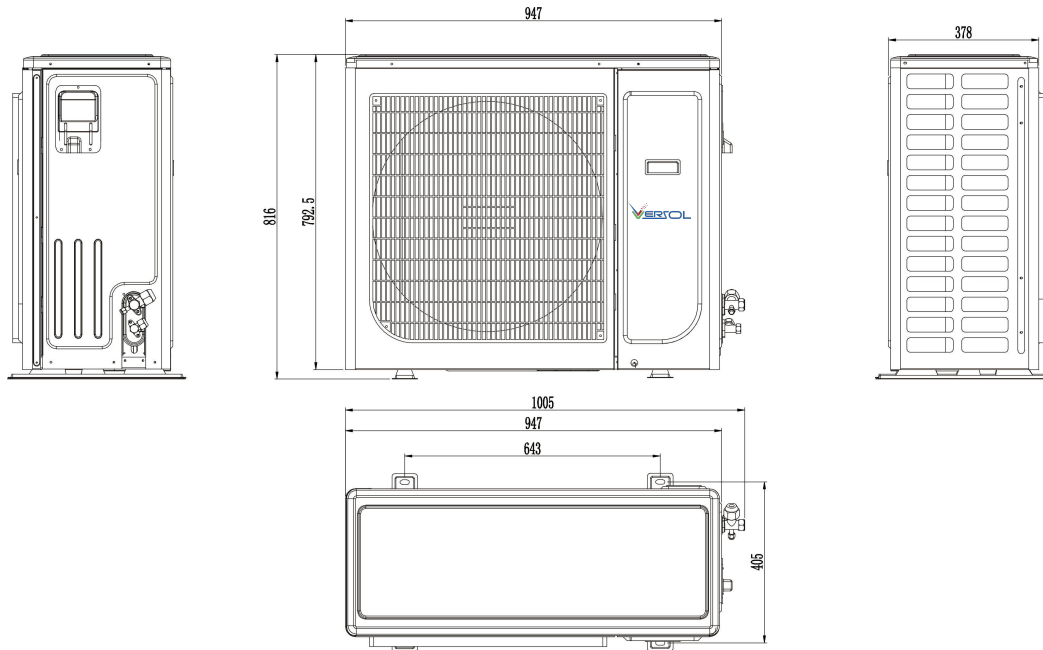

Outdoor unit (Internal): RF8I/bdm

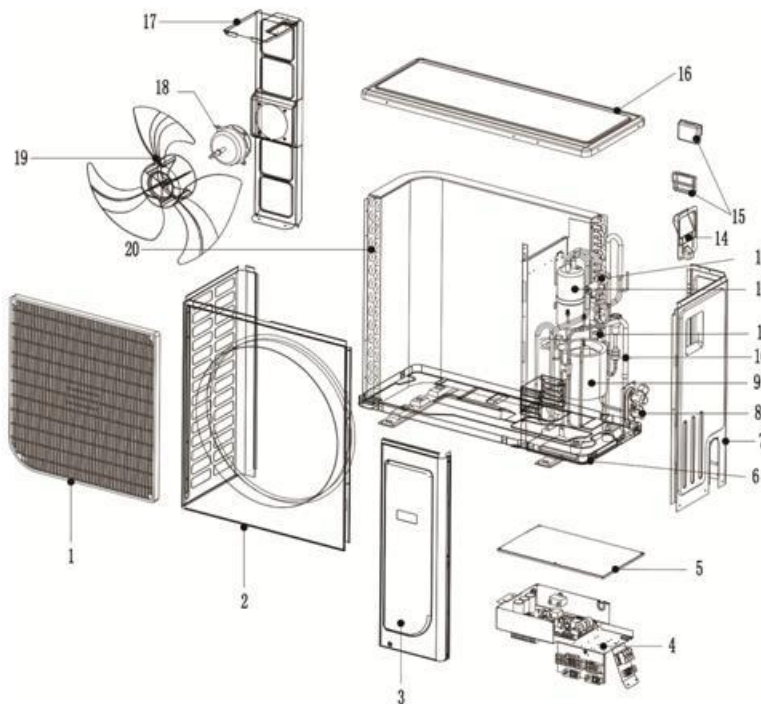

NO.	Name	NO.	Name	NO.	Name
1	Grill	8	Globe valve	15	Small clasp handle
2	Front panel	9	Compressor	16	Top cover
3	Front right side panel	10	Pipe assembly	17	Motor bracket
4	Electronic control component	11	Electronic expansion valve	18	Fan motor
5	Electronic control box cover	12	Gas-liquid separator	19	Fan blade
6	Bottom panel	13	Four way valve	20	Condenser assembly
7	Back right side panel	14	Big handle		

Outdoor unit (External): RF12I/bdm&RF13I/bdm&HF20I/bdm

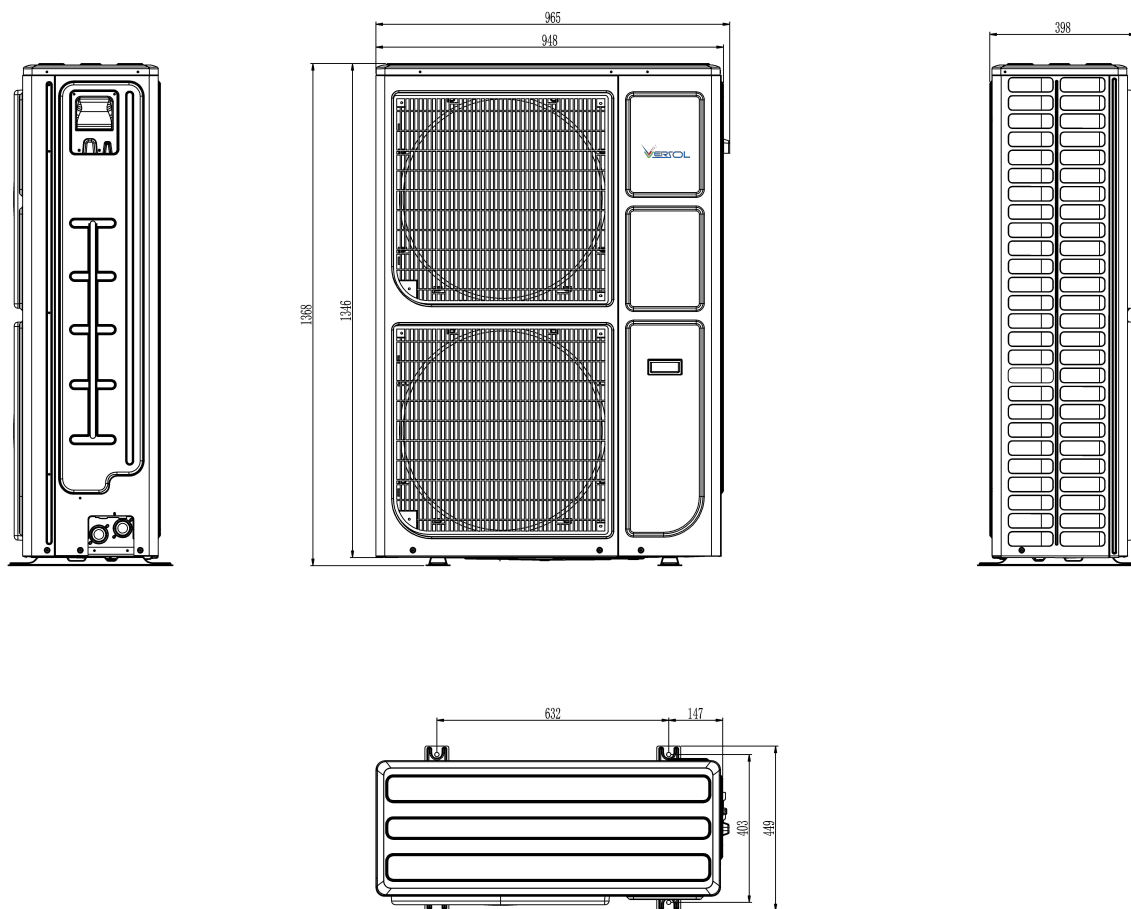

Outdoor unit (Internal) – RF12I/bdm&RF13I/bdm&HF20I/bdm

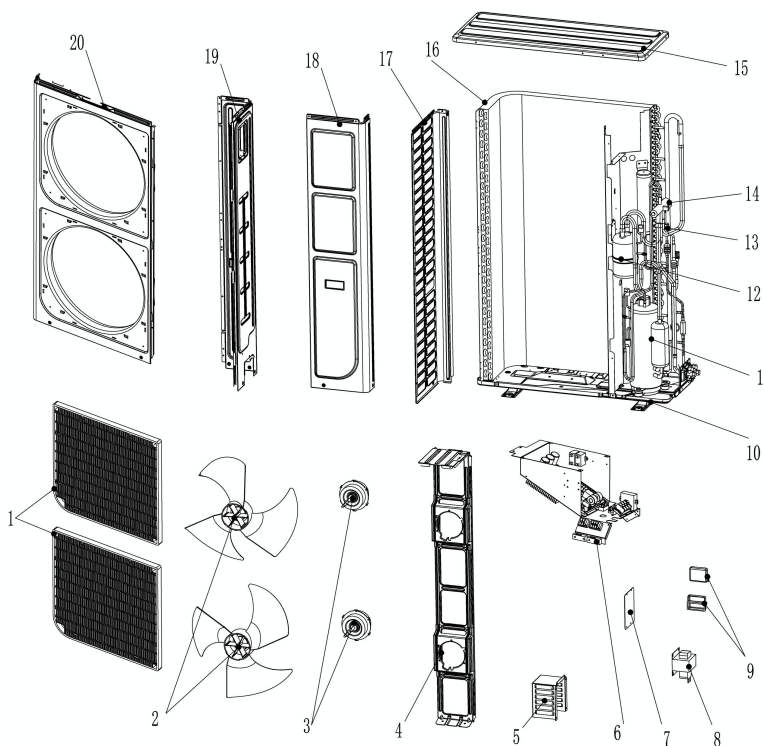

NO.	Name	NO.	Name	NO.	Name
1	Grill	8	Reactor	15	Top cover
2	Fan blade	9	Small clasp handle	16	Condenser
3	Fan motor	10	Bottom plate	17	Left side panel
4	Motor bracket	11	Compressor	18	Front right side panel
5	Reactance waterproof box	12	Gas-liquid separator	19	back right side panel
6	Electronic control box component	13	Electronic expansion valve	20	Front panel
7	Big handle	14	Four way valve		

Schematic diagram of power input connection

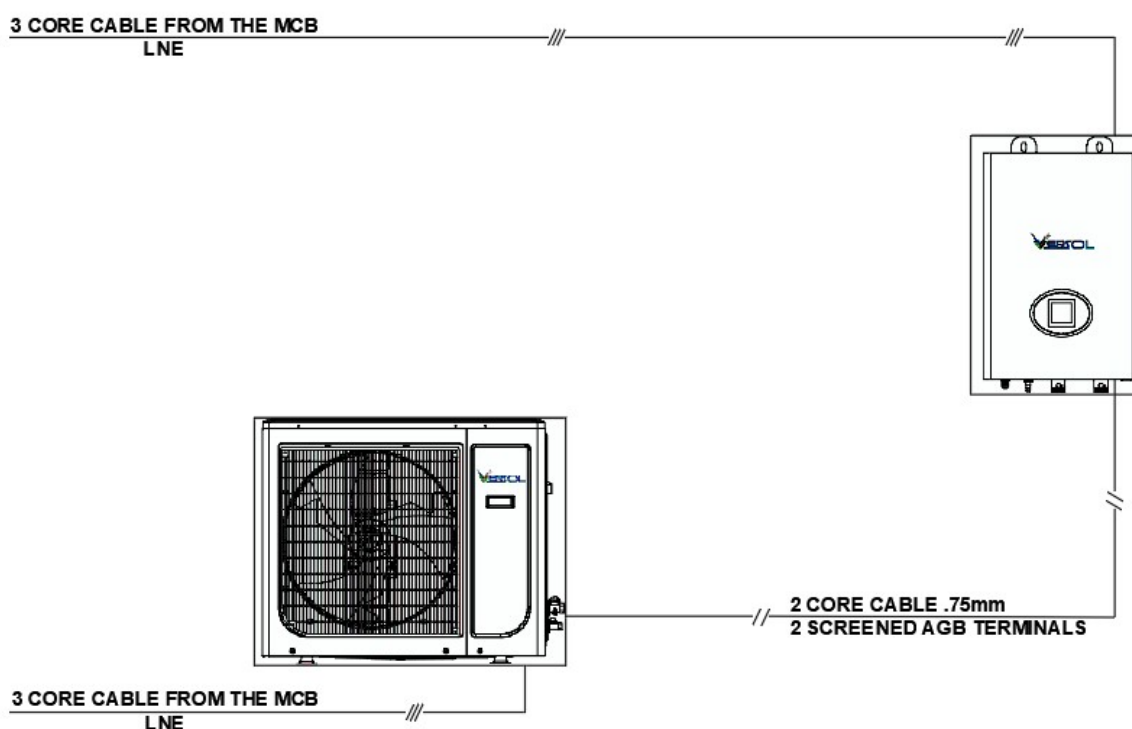

NB cable entry either top or bottom of the indoor unit

Model	Rated Input Power/ Rated Current Outdoor Unit	Indoor Unit
RF8I/bdm	4400W /22A	150W(+ 3000W**) / 0.65A (+13.6 A **)
RF12I/bdm	5200W /24A	150W(+ 3000W**) / 0.65A (+13.6 A **)
RF13I/bdm	6000W /28A	150W(+ 3000W**) / 0.65A (+13.6 A **)
HF20I/bdm		150W(+ 3000W**) / 0.65A (+13.6 A **)
Remark ** related to the supplementary heater.		

Field wiring

WARNING

- A main switch or other means for disconnection, having a contact separation in all poles, must be incorporated in the fixed wiring in accordance with relevant local and national legislation.
- Switch 'off' the power supply before making any connections.
- All field wiring and components must be installed by a licensed electrician and must comply with relevant European and national regulations.
- The field wiring must be carried out in accordance with the wiring diagram supplied with the unit and the instructions given below.
- Be sure to use a dedicated power supply. Never use a power supply shared by another appliance.
- Be sure to establish an earth. Do not earth the unit to a utility pipe, surge absorber, or telephone earth. Incomplete earth may cause electrical shock.
- Be sure to install an earth leakage protector. Failure to do so may cause electrical shock.

Wiring overview

The table below gives a wiring overview of required field wiring.

		RF8I/bdm	RF12I/bdm	RF13I/bdm	HF20I/bdm
United Power supply (outdoor power supply must fuse down the indoor power supply to 20 amps)		AWG9(6mm ²)* ₃	AWG8(10mm ²)* ₃	AWG8(10mm ²)* ₃	
Separated Power supply	Indoor	AWG11(4mm ²)* ₃	AWG11(4mm ²)* ₃	AWG11(4mm ²)* ₃	
	Outdoor	AWG13(4mm ²)* ₃	AWG11(6mm ²)* ₃	AWG11(6mm ²)* ₃	

Control Panel Operation Guideline

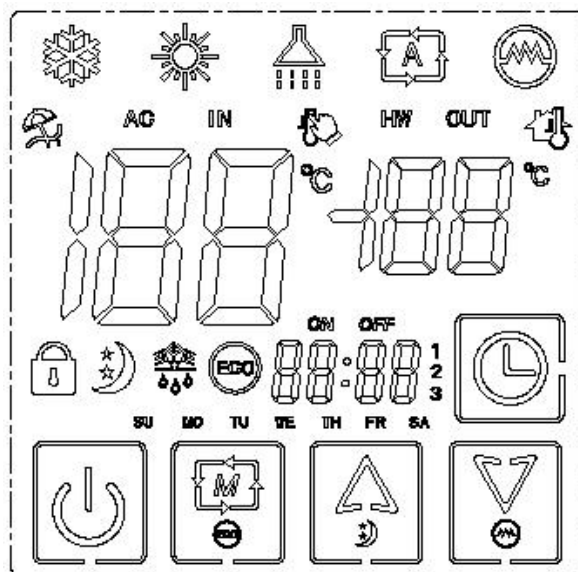

Dip switch setting

	DP1
Celsius	0
Fahrenheit	1

	DP2
Buzzer valid	0
Buzzer invalid	1
	DP3
LED short light	0
LED long light	1

Display interface

1. Complete display interface



2. Mode Icons



Cooling mode icon;
 Heating mode icon;
 Hot water mode icon;
 Auto operation mode icon;
 Icon for mandatory electric heating mode and disinfection

3. Day Icons



SU:Sunday; MO:Monday; TU:Tuesday; WE:Wednesday; TH:Thursday; FR:Friday; SA:Saturday

4. Main Display Area



When main unit type is:

Multi-function unit:display air-conditioning return water temperature

Cool&heat unit:display air-conditioning return water temperature

Hot water unit:display tank temperature

Unit for pool heating or cooling:display return water temperature



It is holiday mode icon,only display when holiday mode is set.



It is temperature setting icon,only display when enter into temperature settings.

5. Second Display Area



When main unit type is:

Multi-function unit:display tank temperature

Cool&heat unit:display air-conditioning water outlet temperature

Hot water unit:display setting temperature





Unit for pool heating or cooling:display water outlet temperature



Indoor temperature icon

6.Function Icon and Clock&Timer Area





 Safety lock;
  Night mode;
  Defrosting and anti-freezing in winter;
  Clock and timer area



7. Touch Screen Keys Area





How to use the keys



 ON/OFF or holiday mode: on/off switch if short press; enter into holiday mode if press this button for 5S. **Any set or query mode, short press this button to exit the setup or query condition.**

 Mode selection /Setup key: switching from different modes if short press; **After up or down to adjust temperature, short click this button to confirm; In Boot mode, long press this key to enter or exit the power saving mode; In saving mode will display  icon.**



 Up: increase temperature or time if short press, enter into night mode if press this key for long time; **On the same time will display  icon.**



 Down: reduce temperature or time if short press, enter into mandatory electric heating (electric heating mode) if press this key for long time. **On the same time will display  icon.**



 Timer or clock settings: **enter into clock time settings if press this key for short time; and enter into timer mode settings if press this key for long time.**



 The first power on, if no any operation for 120 seconds, the LCD will be locked, and display  icon. **After the screen light up, if the screen is locked, long press mode key  for 5s the LCD will be unlocked. (When choose to have automatic lock screen function)**



Combination keys

Press  +  for over 5 seconds, enter into parameter settings; press this combination key again, exist parameter settings.

Press  +  for long time, enter into parameter check mode; press this combination key again for long time, exist parameter check mode.

Long press  +  at same time, enter into checking history failures; long press this combination key again to exist.

In cooling mode, long press  +  to enter into gas recycling mode,  will flash; long press this combination key to exist gas recycling.

When unit is OFF, long press  to enter into holiday mode, only display ; long press this key again to exist holiday mode.

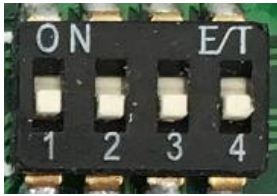

Drawing code definition of line controller:

Drawing code1: Lock screen selection: ON-no operation after 2S , automatically lock screen ; OFF-no automatically lock screen

Drawing code2: Buzzer prompted selection: ON- When operating, buzzer is not responding; OFF- When operating, buzzer is responding;











Drawing code3: Backlight automatically shut down selection: ON-Screen backlight normally ON; OFF- no operation after 30 seconds, screen backlight automatically shut down;

Drawing code4: Screen test mode: ON - screen test state; OFF - screen is normal;







Function Instruction

Water temperature settings

When enter into temperature settings, will display , the settings are different based on different modes:

- 1) If cooling or heating mode; The main display interface display AC and set temperature, Press  or  to change setting value, press  to confirm and exist water temperature settings.
- 2) If hot water mode, the second display interface will display HW and setting temperature, press  or  Change the Settings, press  this icon to confirm and exit temperature settings.
- 3) If air-conditioning+hot water mode, Press  or  will set air-condition temperature firstly, press  to enter into hot water temperature settings, and press  again to confirm and exist water temperature settings.



EEPROM parameter settings

After entering into parameter setting interface , firstly the main and second display area will show 4-digit number "8888", password required. After correct password input, will display "XX YYY", "XX" is parameter type, "YYY" is parameter value. "X" will flash firstly, press  or  to switch from different parameter types, and press  to confirm, then "X" stops flash, "YYY" starts flash entering into parameter value change mode, press  or  to change parameter values, press  to confirm, then "YYY" stop flash, "X" starts flash.

Parameter Check

When enter into parameter setting interface, the display areas will display “XX YYY”, “XX” is parameter number, “YYY” is parameter value. Press  or  to switch different parameters.

History Error Check







When enter into history error check mode, will display “P XX” or “E XX”, “P” is protection, “E” is error. Press  or  to switch different errors, can check 5 history errors.





Safety lock(Design for Children)





Enter the safety lock, in addition to the ON/OFF button, the other ON the control panel buttons will be locked.





Timer







Long press , enter into Timer settings.

The 1st step: mode selection. Firstly mode icon will flash, press  or  to select mode, the selection switching from  +  air-conditioning mode,  hot water mode,  tank disinfection mode, press  to confirm; Every mode can have 3 timers.

The 2nd step: select timer. Press  or  to switch from Timer 1 on, Timer 1 off, Timer 2 on, Timer 2 off, Timer 3 on, Timer 3 off; Press  entering into Timer 1 on settings; Short press  to go back to last step(mode selection).

The 3rd step: select Timer day. Press  or  to select which day to apply, press  to confirm and enter into next step(select the Hour), short press  to go back to last step(select Timer).

The 4th step: select the Hour. Press  or  to select the Hour, press  to confirm and enter into next step; Short press  to go back to last step.

The 5th step: select the Minute. Press  or  to select the Minute. Press  or  to select the Minute, press  to confirm and enter into the next Timer selection(the 2nd step); Short press  to go back to last step;

During Timer settings, short press  or fail to operate for 10 seconds to exist current Timer settings and exist.

Under the holiday mode, all Timer function settings will be invalid.











Delete timer setting, after enter into timer operation mode, long press  key Until exit timer state

Clock Display

Clock includes: Day, hour and minute, and the hour uses 24-hour-system;

Clock always displays on screen, no matter the unit is running or not.

Clock settings

Short press  enter into clock setting. When entering into clock settings, firstly the “Day” starts flashing, press  or  to select the Day, press  to confirm and enter into the “Hour” setting, it starts flashing, press  or  to select the Hour, press  to confirm and enter into the “Minute” setting, the “Minute” flashing, press  or  to select the Minute, after finishing settings, press  to confirm and complete clock settings.

EEPROM parameter

No.	Parameter Name	Default Value	Unit	Range	Accuracy
1	Air-conditioning water temperature difference	2	°C	2~5	1
2	Hot water temperature difference	5	°C	0~10	1
3	System parameter	0	°C	0~15	1
4	EEV Superheat under heating	-1	°C	-5~10	1
5	System parameter	68	Hz	20~120	1
6	System parameter	68	Hz	20~120	1
7	System parameter	68	Hz	20~120	1
8	System parameter	250/5	P	(0~480)/5	1
9	System parameter	150/5	P	(0~480)/5	1
10	System parameter	150/5	P	(0~480)/5	1
11	Defrosting enter temperature	-5	°C	-15~0	1
12	Defrosting entry temperature difference	5	°C	0~15	1
13	System parameter	40	Min	20~90	1
14	System parameter	480/5	P	(0~480)/5	1
15	Compressor frequency under defrosting	60	Hz	20~120	1
16	System parameter	95	Hz	20~120	1
17	Power lost memory	1	0/1	0-without 1-with	/
18	Frequency limits under low noise mode	55	Hz	20~120	1
19	Disinfection set temperature	65	°C	55~75	1
20	Disinfection lasting time	30	Min	20~120	1

21	Mode priority	0	0/1/2	0-hot water priority 1-aircon priority 2-first impression are strongest	/
22	System parameter	0	Hz	20~120	1
23	System parameter	0	Hz	20~120	1
24	System parameter	0	Hz	20~120	1
25	System parameter	0	Hz	20~120	1
26	Electrical heating water tank open ambient temperature	4	°C	-10~40	1
27	Auto temperature compensation valid or invalid	0		0-on 2min/stop 5min 1-keep running	1
28	Compensation high point	5	°C	10~20	1
29	Compensation low point	0	°C	-20~5	1
30	The maximum compensation value	5	°C	0~10	1
31	High temperature stop unit valid or invalid	0		0/1(1-valid 0-invalid)	1
32	High temperature stop unit setting	24	°C	10~30	1
33	Economical modes setting	10	°C	5~20	1
34	Water pump setting	1	0/1	0-on 2min/stop 5min 1-keep running	1
35	Low temperature stop compressor setting	-25	°C	-30~10	1
36	Pipe electric heater being valid or invalid	0	0/1	0-valid 1-invalid	1
37	Cooling mode if being valid or not	0		0-valid 1-invalid	1
38	System parameter	0	0/1	0-valid 1-invalid	1
39	System parameter	80/5	P	0-480/5	1
40	System parameter	15	°C	0~40	1
41	Tube electric heater running ambient temperature	-5	°C	-15~20	1
42	Exit defrosting temperature	15	°C	10~25	1
43	Defrost longest running time	10	min	1~20	1
44	System parameter	50		20~60	1
45	System parameter	2		0/1/2	1

Main Errors and Protection

Error Code	Error Name	Error Analysis	Diagnostic Method	Solution
P01	Water flow protecting	<ol style="list-style-type: none"> 1. System hydropenia 2. Flow switch fault 3. System blocking 	<ol style="list-style-type: none"> 1. check the water injection valve whether is off or cut off the water supply; 2. check the flow switch whether is blocking or break off; 3. Check the Y type filter whether is blocking. 	<ol style="list-style-type: none"> 1. open the valve 2. Change the water flow switch 3. clean or change filter net
P02	High pressure protection	<ol style="list-style-type: none"> 1. lower flow; 2. high pressure switch fails; 3. Cooling system blocked; 4. EEV valve locked. 	<ol style="list-style-type: none"> 1. check if system lack of water or insufficient pump water flow; 2. check if high pressure switch cuts if unit OFF; 3. ck if cooling system filter blocked; 4. ck if any EEV reset sound when power off and on under unit OFF mode. 	<ol style="list-style-type: none"> 1. Refill water or change bigger flow pump or add a booster pump; 2. change high pressure switch; 3. change filter; 4. change EEV valve.
P03	Low pressure protection	<ol style="list-style-type: none"> 1. Lack refrigerant 2. refrigeration system blocking 3. beyond system working range 	<ol style="list-style-type: none"> 1. check the system whether is leaking 2. Check the filter net whether is blocking 3. check the ambient temperature or water temperature whether is beyond limit 	<ol style="list-style-type: none"> 1. leak repairing and inject refrigerant again; 2. change the filter; 3. Beyond system limit can't opening.
P04	T3 coil over-heat protection	<ol style="list-style-type: none"> 1. tdoor fan vent blocked 2. tdoor heat exchanger blocked; 3. sensor temperature deviation. 	<ol style="list-style-type: none"> 1. check if outdoor fan vent blocked; 2. check outdoor heat exchanger blocked; 3. check outdoor temperature sensor resistance vaue if correct. 	<ol style="list-style-type: none"> 1. clean outdoor fan vent ; 2. heat exchanger; 3. change temperature sensor.

P05	Exhaust gas temperature protection	1. System lack of gas; 2. exhaust gas sensor temperature deviation.	1. check system if any leakage; 2. check exhaust gas temperature sensor resistance value if correct.	1. Fix leakage and recharge gas; 2. change temperature sensor.
P06	Outlet water temperature anti-freezing protection	1. lower water flow; 2. heat exchanger blocked; 3. Y-shaped filter blocked; 4. Overflow load.	1. check if air exists in water system; 2. Plate heat exchanger if blocked; 3. check if Y-shaped filter has block; 4. check design of indoor water system if reasonable, if have water bypass.	1. drain valve has problem, change a new one; 2. low plate heat exchanger with water or high-pressure gas through reverse direction; 3. an Y-shaped filter; 4. water system must have bypass.
P07	Pipe temperature anti-freezing protection	1. system lack of gas; 2. water system has block; 3. cooling system has block.	1. check system if any leakage; 2. check Y-shaped filter has block; 3. check if cooling system filter has block.	1. fix leakage and re-charge gas; 2. clean Y-shaped filter; 3. change filter.
P08	High-pressure 2 protection	High pressure switch 2 cuts	check if high pressure switch 2 cuts under unit OFF condition	change high pressure switch 2
E01	Controller communication failure	Communication cable cuts	Check communication cable if cut	Change connection cable or re-connect
E02	TP1 exhaust gas temperature sensor failure	sensor temperature deviation or cuts	Check sensor resistance value or if sensor cuts	Change sensor or re-connect cable
E03	T3 coil temperature sensor failure	sensor temperature deviation or cuts	Check sensor resistance value or if sensor cuts	Change sensor or re-connect cable
E04	T4 ambient temperature sensor failure	sensor temperature deviation or cuts	Check sensor resistance value or if sensor cuts	Change sensor or re-connect cable
E05	T5 liquid gas temperature sensor	sensor temperature deviation or cuts	Check sensor resistance value or if sensor cuts	Change sensor or re-connect cable

E06	TH return gas temperature sensor failure	sensor temperature deviation or cuts	Check sensor resistance value or if sensor cuts	Change sensor or re-connect cable
E07	TW water tank temperature sensor failure	sensor temperature deviation or cuts	Check sensor resistance value or if sensor cuts	Change sensor or re-connect cable
E08	T6 inlet water temperature sensor failure	sensor temperature deviation or cuts	Check sensor resistance value or if sensor cuts	Change sensor or re-connect cable
E09	T7 outlet water temperature sensor failure	sensor temperature deviation or cuts	Check sensor resistance value or if sensor cuts	Change sensor or re-connect cable
E10	Controller and Drive PCB Communicate failure	Communication cable cuts	Check communication cable if cut	Change connection cable or re-connect
E11	reserved	<p style="text-align: center;">Wiring error or IPM module invalid Check if wiring error Re-connect cable or change IPM module</p>		
E12	reserved			
E13	reserved			
E14	reserved			
E15	DC main cable voltage extra low			
E16	DC main cable voltage extra high			
E17	AC current protection (input side)			
E18	IPM module abnormality			
E19	PFC abnormality			
E20	Compressor start failure			
E21	Compressor lack phase			
E22	IPM module reset			

E23	Compressor over-current
E24	PFC module extra high temperature
E25	Current detection Circuit failure
E26	out of step
E27	PFC module temperature sensor abnormality
E28	communication failure
E29	IPM module extra high temperature
E30	IPM module temperature sensor failure
E31	reserved
E32	IPM adjustment data
E33	IPM adjustment data
E34	AC input voltage abnormality
E35	IPM adjustment data
E36	Reserved
E37	IPM module current frequency limits
E38	IPM module voltage frequency limits

Outdoor Unit Electrical Wiring Diagram for the 9KW

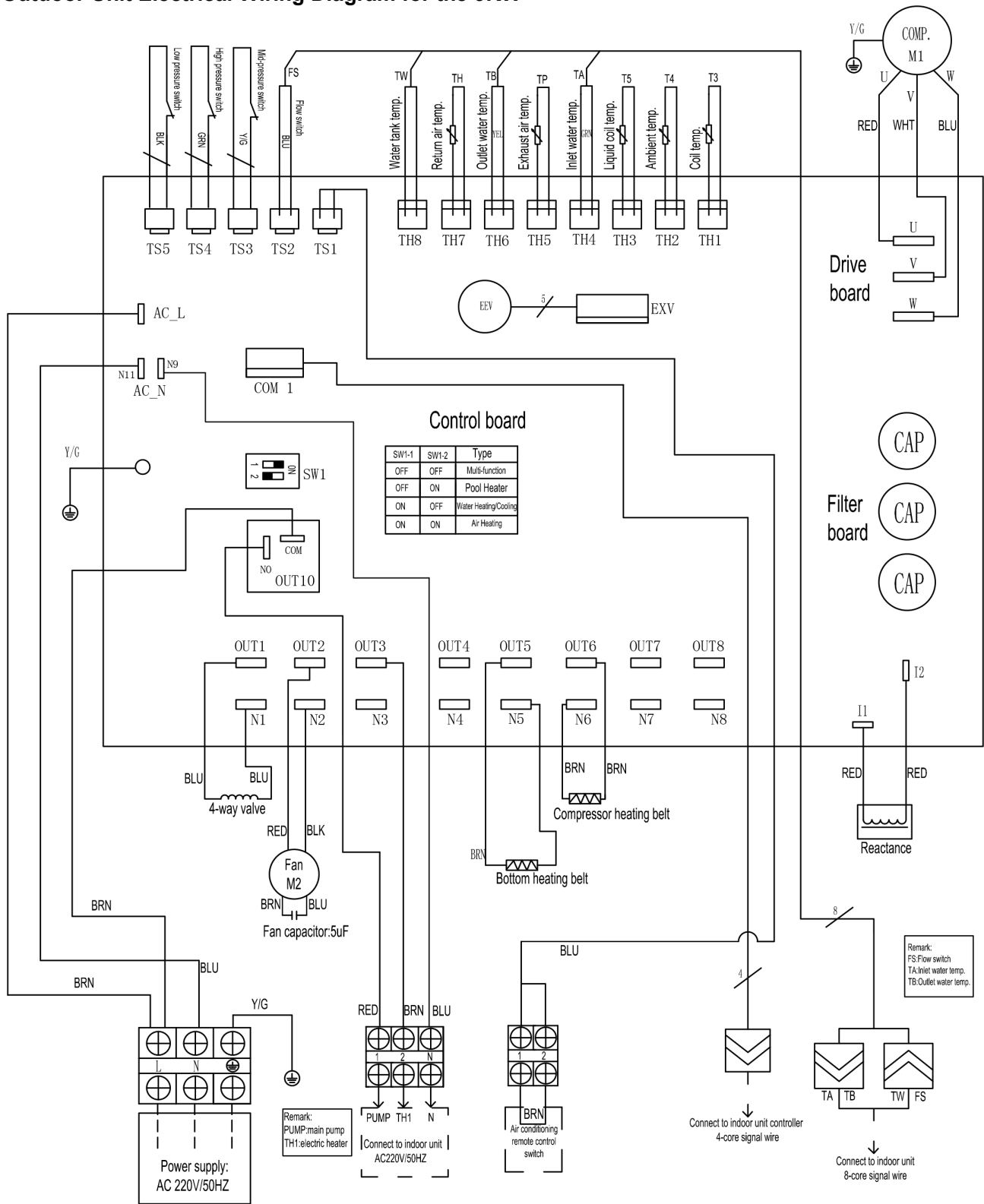

Outdoor Unit Electrical Wiring Diagram for the 12KW

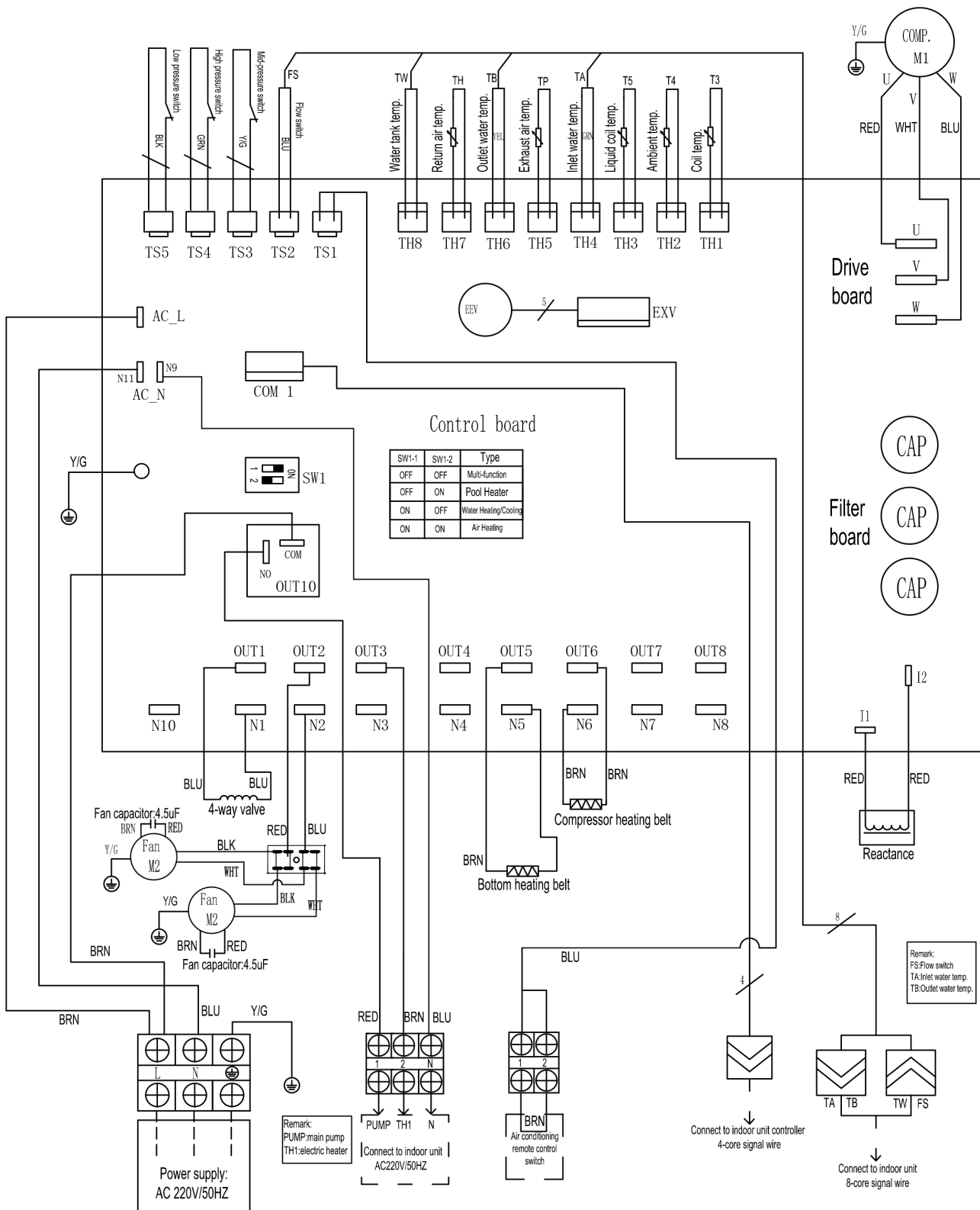

Outdoor Unit Electrical Wiring Diagram for the 15-18KW

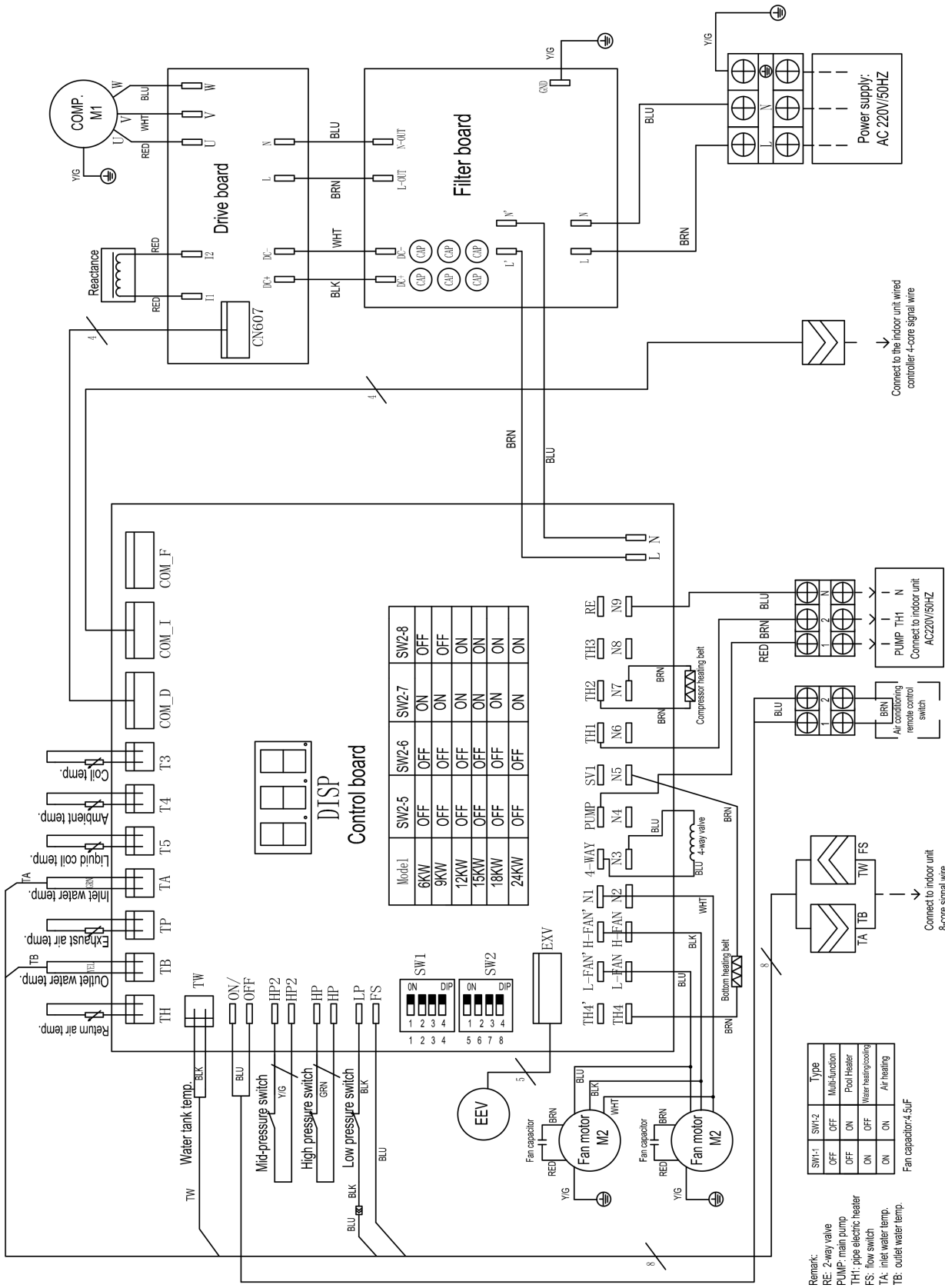

Indoor Unit Electrical Wiring Diagram 9-18KW

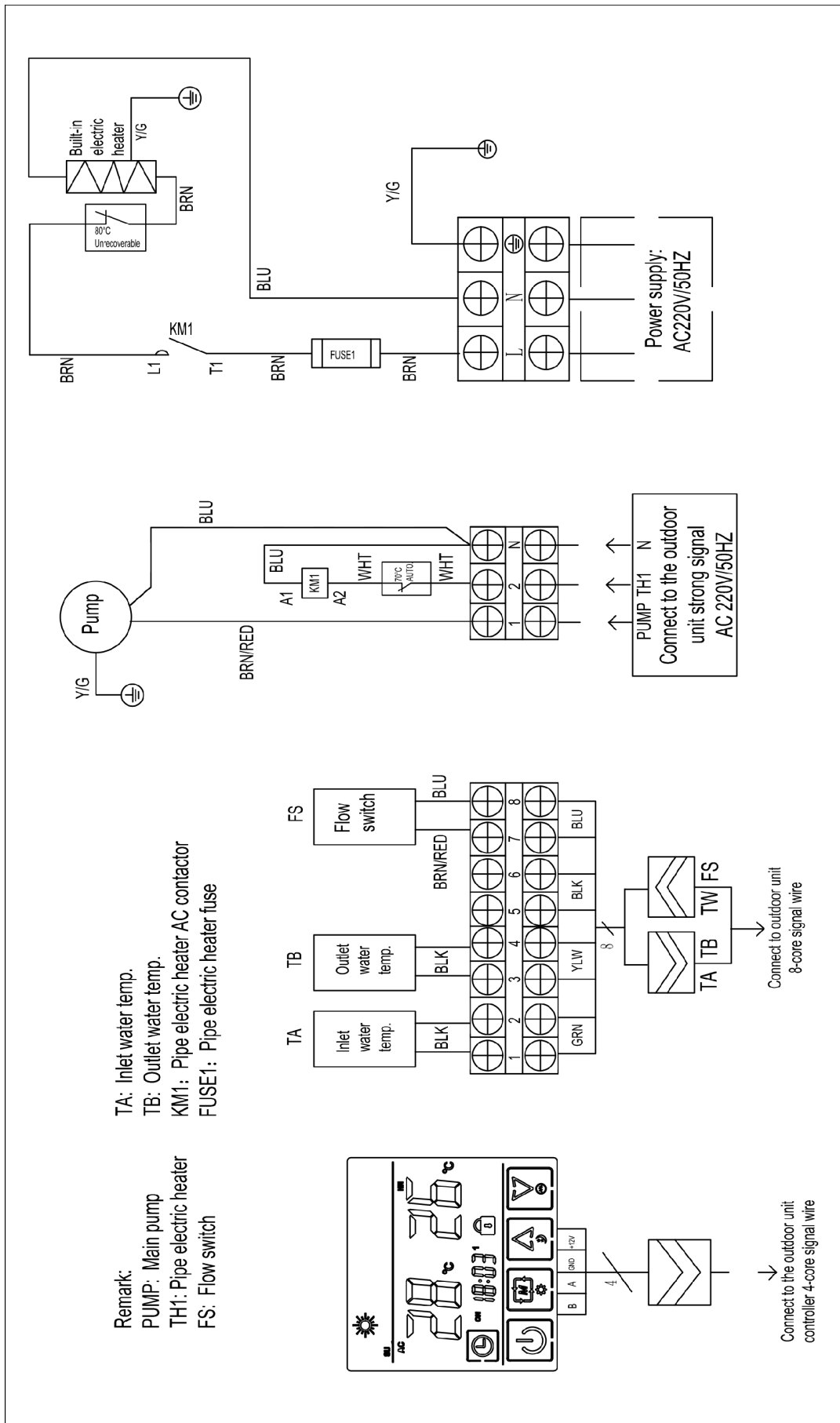

INSTALLATION OF INDOOR UNIT

Selecting an installation location

The indoor unit is to be wall mounted in an indoor location that meets the following requirements:

- The installation location is frost-free.
- The space around the unit is adequate for servicing.
- The space around the unit allows for sufficient air circulation.
- There is a provision for a condensate drain and pressure relief valve blow-off.
- The installation surface is a flat and vertical non-combustible wall, capable of supporting the operation weight of the unit.
- There is no danger of fire due to leakage of inflammable gas.
- All piping lengths and distances have been taken into consideration.

**NB; The pipe connections for the Water & Refrigeration is either top or bottom entry.
Drain connection is at the bottom**

RF8I/bdm- HF20I/bdm Installing cardboard

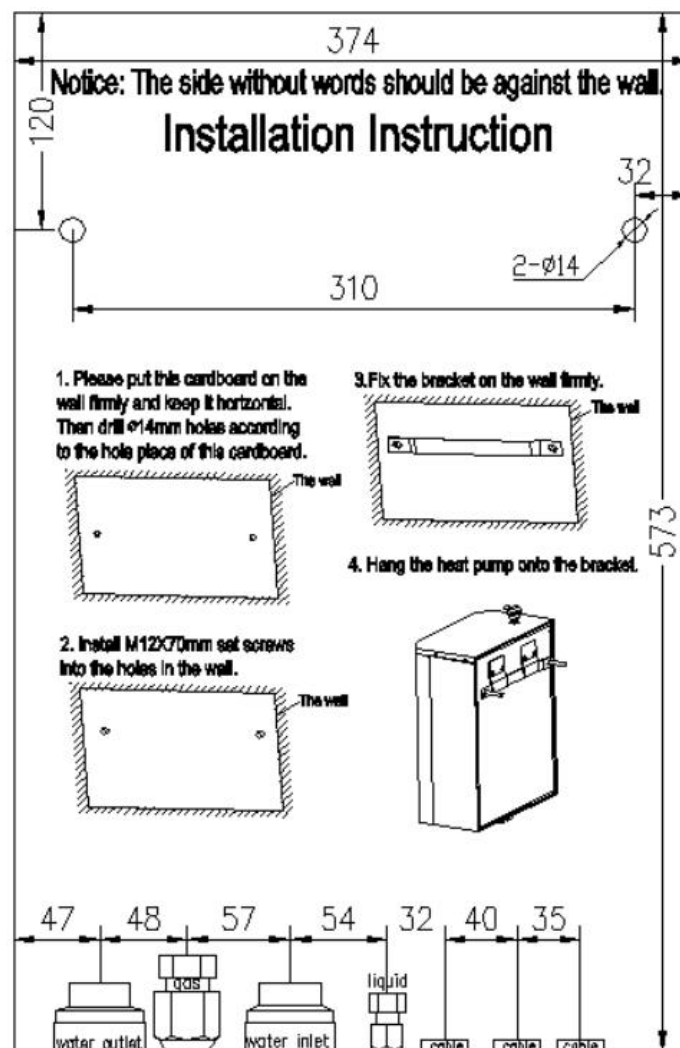

Water pipework

Checking the water circuit

Note: Be sure to install Y-type filter at the inlet

Before continuing the installation of the unit, check the following points:

- The maximum water pressure is 10 barg.
- Shut-off valves are not included with the unit. To facilitate service and maintenance, please install one at each water inlet/outlet. Mind position of the shut-off valves. Orientation of the integrated drain and fill valves is important for servicing.
- Drain taps must be provided at all low points of the system to permit complete drainage of the circuit during maintenance.
- Make sure to provide a proper drain for the pressure relief valve to avoid any water coming into contact with electrical parts.
- Air vents must be provided at all high points of the system. The vents should be located at points which are easily accessible for servicing. An automatic air purge is provided inside the indoor unit. Check that this air purge valve is not tightened too much so that automatic release of air in the water circuit remains possible.
- Take care that the components installed in the field piping can withstand the water pressure.

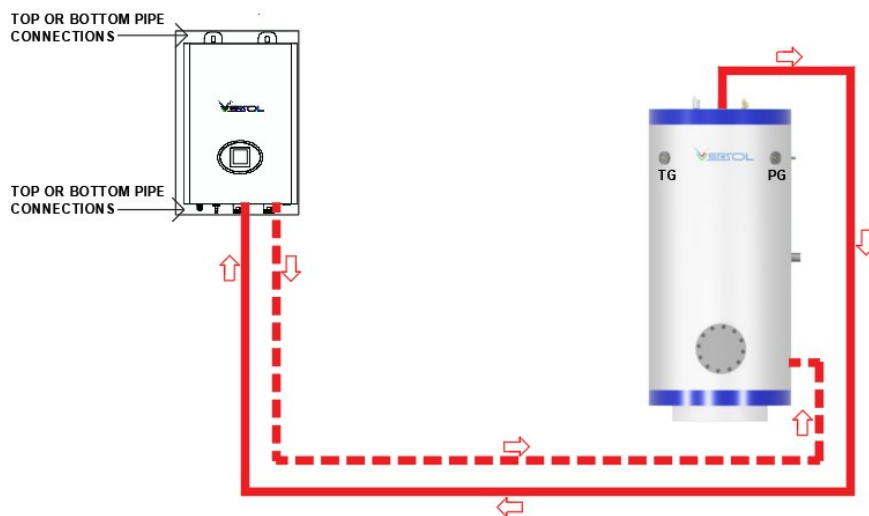

! NEVER USE UN-COATED PARTS IN THE WATER CIRCUIT. EXCESSIVE CORROSION OF THESE PARTS MAY OCCUR AS COPPER PIPING IS USED IN THE INTERNAL WATER CIRCUIT OF THE UNIT.

! WHEN USING A 3-WAY VALVE OR A 2-WAY VALVE IN THE WATER CIRCUIT, THE RECOMMENDED MAXIMUM CHANGEOVER TIME OF THE VALVE SHOULD BE LESS THAN 20 SECONDS.

Charging water

1. Connect the water supply to a drain and fill valve.
2. Make sure the automatic air purge valve is open (at least 2 turns).
3. Fill with water until the water manometer indicates a pressure of approximately 2.0 bar. Remove air in the circuit as much as possible using the air-purge valves. Air present in the water circuit might cause malfunctioning of the optional backup heater.
4. **Backup heater:**
Check that the backup heater vessel is filled with water by opening the pressure relief valve. Water

must flow out of the valve.

 **NOTE**

- During filling, it might not be possible to remove all the air in the system. Remaining air will be removed through the automatic air purge valves during first operating hours of the system. Additional filling with water afterwards might be required.
- The water pressure indicated on the water manometer will vary depending on the water-temperature (higher pressure at higher water temperature).
- However, at all times water pressure should remain above 0.3 barg to avoid air entering the circuit.
- The unit might dispose some excessive water through the pressure relief valve.
- Water quality must be according to EN directive 98/83 EC.

Water Flow Rates

9kw	1.38 m ³ /h
15kw	1.80 m ³ /h
18kw	1.98 m ³ /h
20kw	2.06 m ³ /h

INSTALLATION OF THE OUTDOOR UNIT

Installation guidelines

Precautions for selecting the location

WARNING

- !** MAKE SURE TO PROVIDE FOR ADEQUATE MEASURES IN ORDER TO PREVENT THAT THE OUTDOOR UNIT WILL BE USED AS A SHELTER BY SMALL ANIMALS.
 - !** SMALL ANIMALS MAKING CONTACT WITH ELECTRICAL PARTS CAN CAUSE POSSIBLE MALFUNCTIONS, SMOKE OR FIRE. PLEASE KEEP THE AREA AROUND THE UNIT CLEAN.
1. Choose a place solid enough to bear the weight and vibration of the unit, where the operation noise will not be amplified.
 2. Choose a location where the hot air discharged from the unit or the operation noise will not cause a nuisance to the neighbors of the user.
 3. Avoid places near a bedroom and the like, so that the operation noise will cause no trouble.
 4. There must be sufficient space for carrying the unit into and out of the site.
 5. There must be sufficient space for air passage and no obstructions around the air inlet and the air outlet.
 6. The site must be free from the possibility of flammable gas leakage in a nearby place.
 7. Install units, power cords and inter-unit cables at least 3m away from television and radio sets. This is to prevent interference to images and sounds.
 8. Depending on radio wave conditions, electromagnetic interference can still occur even if installed more than 3m away.
 9. In coastal areas or other places with salty atmosphere of sulfate gas, corrosion may shorten the life of the outdoor unit.
 10. The water will flow out of the outdoor unit when in defrost, do not place anything under the unit which must be kept dry.

Installation space

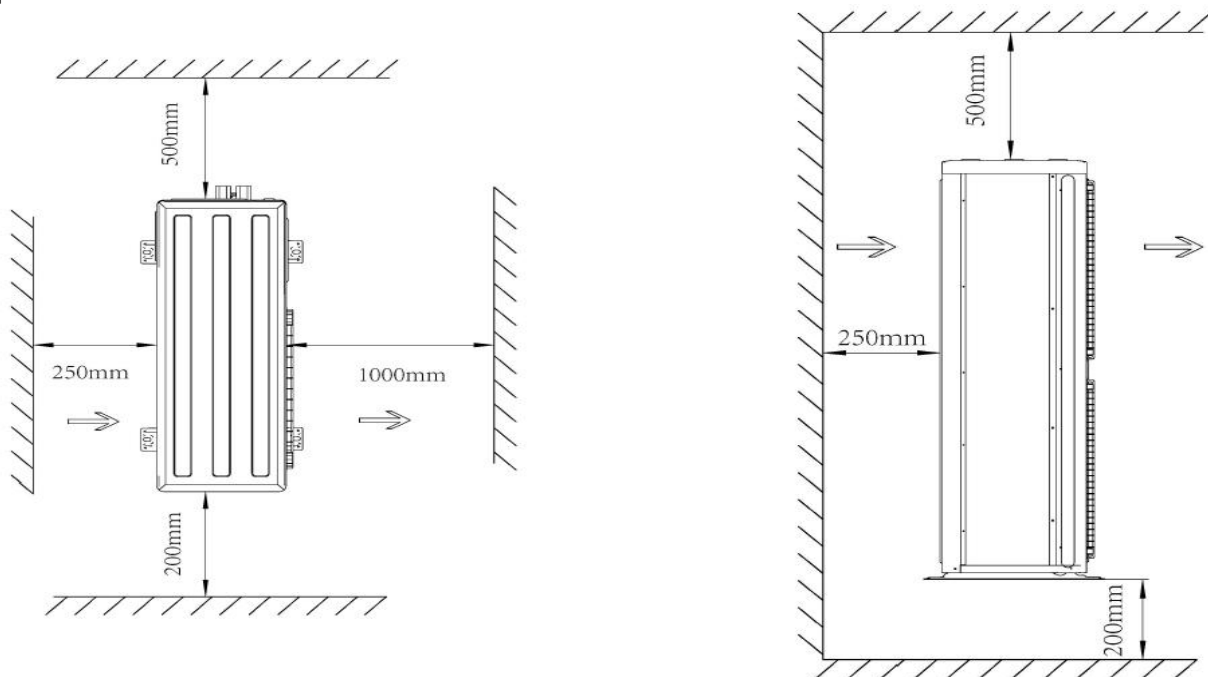

Installation procedure

Mounting the outdoor unit

When installing the outdoor unit, please refer to “Installation guidelines” to select an appropriate location.

1. Check the strength and level of the installation ground so that the unit will not cause any operating vibration or noise after installation.
2. Prepare 4 sets of M8 foundation bolts, nuts and washers each (filed supply).
3. Fix the unit securely by means of the foundation bolts in accordance with the foundation drawing. It is

best to screw in the foundation bolts until their length remains 20mm above the foundation surface.

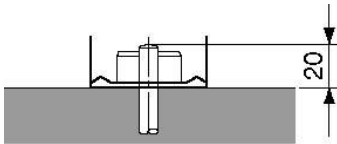

NB; Wall brackets are not supplied with the outdoor unit unless specified an installation guide is supplied within the wall brackets packaging

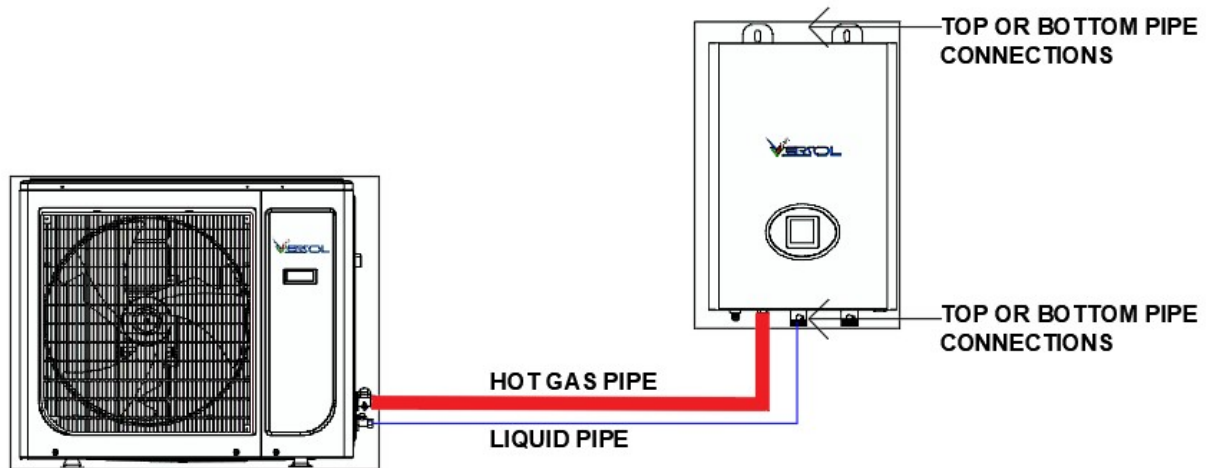

Refrigerant pipe-work

For all guidelines, instructions and specifications regarding refrigerant pipe-work between the indoor unit and the outdoor unit please refer to the installation of outdoor unit.

The location of the gas pipe and liquid pipe on the unit is shown under the overview of the unit.

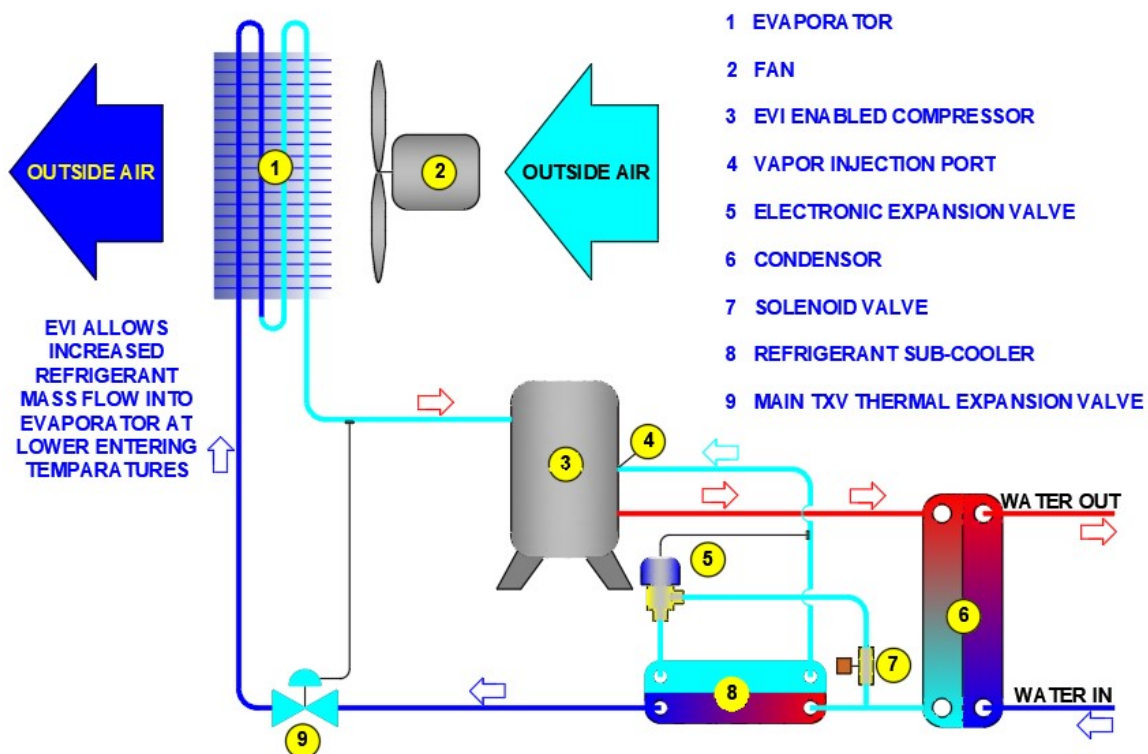

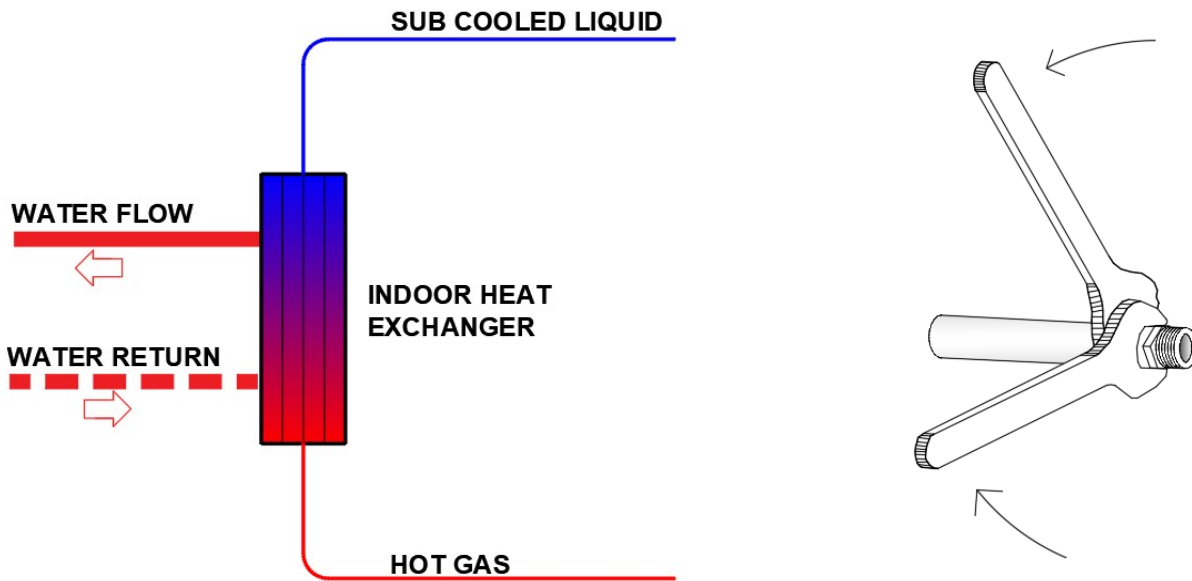

WHEN CONNECTING THE REFRIGERANT PIPES, ALWAYS USE TWO WRENCHES/SPANNERS FOR TIGHTENING OR LOOSENING NUTS!
FAILURE TO DO SO CAN RESULT IN DAMAGED PIPING CONNECTIONS AND LEAKS.

NB When brazing the pipe always purge with OFN

Installation of the interconnecting pipe work

! ALL FIELD PIPING MUST BE INSTALLED BY A LICENSED REFRIGERATION TECHNICIAN AND MUST COMPLY WITH RELEVANT LOCAL AND NATIONAL REGULATIONS

Flaring the pipe end

To flare each pipe end, follow the procedure below:

1. Cut the pipe end with a pipe cutter.
2. Remove burrs with the cut surface facing downward so that the chips do not enter the pipe.



- | |
|---------------------------------|
| 1. Cut exactly at right angles. |
| 2. Remove burrs. |

3. Remove the flare nut from the stop valve and put the flare nut on the pipe.
4. Flare the pipe. Set exactly at the position shown below.

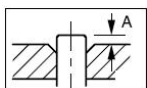

		Conventional flare tool	
		Clutch type (Rigid-type)	Wing nut type (Imperial-type)
A	Flare tool for R410A (clutch type) 0-0.5 mm	1.0-1.5 mm	1.5-2.0 mm

Check that the flaring is properly made.

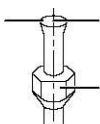

- | |
|--|
| 1. Flare's inner surface must be flaw-free. |
| 2. The pipe end must be evenly flared in a perfect circle. |
| 3. Make sure that the flare nut is fitted. |

CAUTION

- Do not use mineral oil on flared part.
- Mineral oil getting into the system would reduce the lifetime of the units.
- Never use piping which has been used for previous installations. Only use parts which are delivered with the unit.
- Never install a drier to this R410A unit in order to guarantee its lifetime. The drying material may dissolve and damage the system.
- Incomplete flaring may cause refrigerant gas leakage.

1. When connecting the flare nut, coat the flare inner surface with ether oil or with ester oil and initially tighten 3 or 4 turns by hand before tightening firmly.

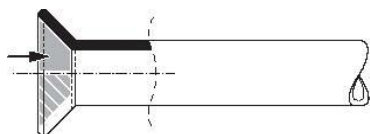

2. When loosening a flare nut, always use two wrenches together. When connecting the piping, always use a spanner and torque wrench together to tighten the flare nut to prevent nut cracking and leaks.

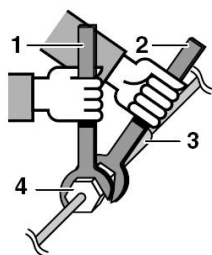

- 1 Torque wrench
- 2 Spanner
- 3 Piping union
- 4 Flare nut

Outside diameter		Torque
mm	Inch	Kgf.m
6.35	1/4	1.8 ~ 2.5
9.52	3/8	3.4 ~ 4.2
12.7	1/2	5.5 ~ 6.6
15.88	5/8	6.6 ~ 8.2
19.05	3/4	9.9 ~ 12.1

Refrigerant piping work
Pipe handling guidelines

- Protect the open end of the pipe against dust and moisture.
- All pipe bends should be as gentle as possible. Use a pipe bender for bending.
- Bending radius should be 30 to 40 mm or larger.

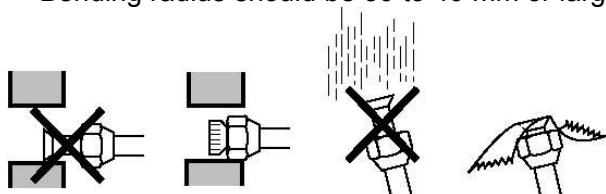

Selection of copper and heat insulation materials

When using commercial copper pipes and fittings, observe the following:

- Insulation material: polyethylene foam
Heat transfer rate: 0.041 to 0.052 W/mK (0.035 to 0.045 kcal/mh°C)
Refrigerant gas pipe's surface temperature reaches 110°C max.

Choose heat insulation materials that will withstand this temperature.

- Be sure to insulate both the gas and liquid piping and to provide insulation dimensions as below.

Pipe size		Pipe insulation	
Outer diameter	Thickness	Inner diameter	Thickness
9.52 mm (3/8")	≥0.75 mm	10-12 mm	≥10 mm
15.88 mm (5/8")	≥1.0 mm	20-24 mm	≥13 mm

- Use separate thermal insulation pipes for gas and liquid refrigerant pipes.

Purging air and checking gas leakage

When all piping work is completed and the outdoor unit is connected to the indoor unit, it is necessary to purge the air and check for gas leakage.



WARNING

- Do not mix any substance other than the specified refrigerant (R410A) into the refrigeration cycle.
- When refrigerant gas leaks occur, ventilate the room as soon and as much as possible.
- R410A, as well as other refrigerants, should always be recovered and never be released directly into the environment.

⚠ CAUTION

- Use a vacuum pump for R410A exclusively. Using the same vacuum pump for different refrigerants may damage the vacuum pump or the unit.
- If using additional refrigerant, perform air purging from the refrigerant pipes and indoor unit using a vacuum pump, then charge additional refrigerant.
- Use a hexagonal wrench (4 mm) to operate the stop valve rod.
- All refrigerant pipe joints should be tightened with a torque wrench at the specified tightening torque. See "Connecting the refrigerant piping to the outdoor unit" for details.

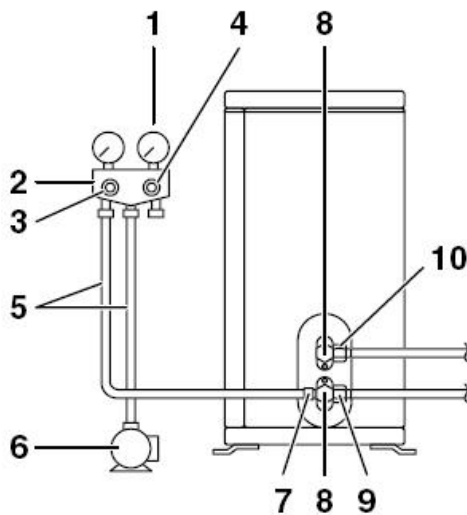

- | | |
|----|--------------------------|
| 1 | Pressure meter |
| 2 | Gauge manifold |
| 3 | Low-pressure valve (Lo) |
| 4 | High-pressure valve (Hi) |
| 5 | Charging hoses |
| 6 | Vacuum pump |
| 7 | Service port |
| 8 | Valve lids |
| 9 | Gas stop valve |
| 10 | Liquid stop valve |

How to perform a pressure leak test (PLT)

1. Once the system is installed a strength test can be performed ensuring that you use OFN (Oxygen free nitrogen) this should comply with EN 378 maximum working pressure plus 10% this is to be observed for 15-20 mins. Ensure that you use the correct leak testing equipment whilst under the strength test ie soapy bubbles. **NB the final connection cannot be connected to the outdoor unit as this may cause nitrogen contamination passing through the service valves.**
2. If the leak or leaks have been found then you, can release the nitrogen and fix the leak. **NB Never fix any leak whilst the system is under pressure**
3. If the leak is not found other methods should be adopted ie a trace charge whilst using an electronic leak detector, Florescent fluid under a UV light or a trace of Hydrogen / Helium
4. After all leaks are found and fixed then connect to the outdoor unit service valves and then a pressure test can be conducted and should be tested to 150 psig for 8 hours and ensure there is no pressure loss **NB Nitrogen can increase and decrease dependent on temperature.**
5. After the pressure test you can now conduct air purging via a vacuum pump the ideal vacuum is around the 2 Torr once achieved you must conduct a pressure rise test.
6. After all this is conducted, you can now recharge the system with the correct refrigerant charge using virgin refrigerant.
7. commission the system and conduct a full run test

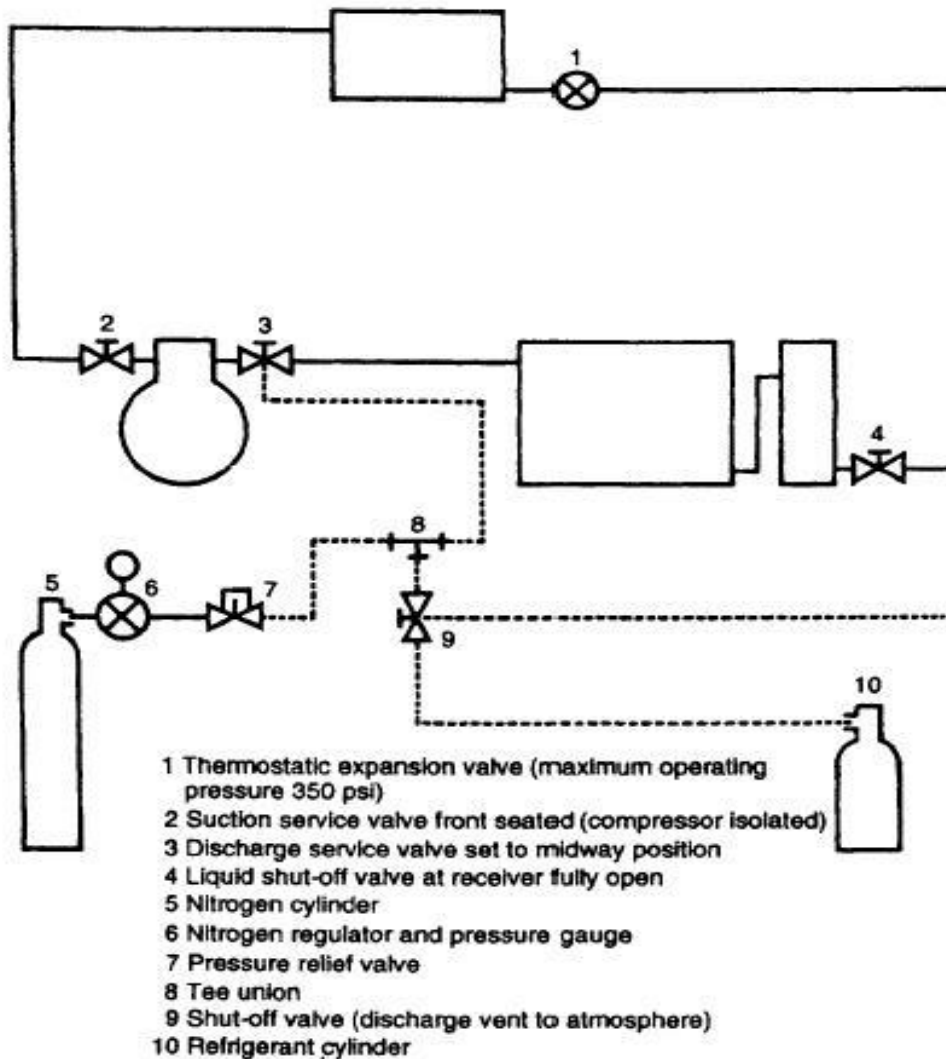

Figure 9 Typical test arrangement for leak testing at 300 psi

Charging refrigerant

This outdoor unit is factory charged.

Important information regarding the refrigerant used

This product contains fluorinated greenhouse gases covered by the Kyoto Protocol. Do not vent gases into the atmosphere.

Refrigerant type: R410A

GWP⁽¹⁾ value: 1975

⁽¹⁾ GWP = global warming potential

NOTE: National implementation of EU regulation on certain fluorinated greenhouse gases may require this text in the appropriate official language on the unit. Therefore, an additional multilingual fluorinated greenhouse gases label is supplied with the unit.

Sticking instructions are illustrated on the backside of that label.

Re-charging

In case re-charging is required, refer to the nameplate of the unit. The nameplate states the type of refrigerant and necessary amount.

Charging additional refrigerant

Refrigerant piping specifications	RF8I/bdm	RF12I/bdm	RF13I/bdm	HF20I/bdm
Maximum allowable piping length between outdoor unit and indoor unit	10m	15m	15m	15m
Maximum allowable height difference between outdoor unit and indoor unit	5 m	8 m	8m	8m
Additional refrigerant required for refrigerant pipe exceeding 5 m in length	55 g/m	55 g/m	55/m	55/m
Gas pipe	15.88 mm (5/8")	15.88 mm (5/8")	15.88mm (5/8")	15.88mm (5/8")
Liquid pipe	9.52 mm (3/8")	9.52mm (3/8")	9.52mm (3/8")	9.52mm (3/8")

Precautions when adding R410A

- Be sure to charge the specified amount of refrigerant in liquid state to the liquid pipe. Since this refrigerant is a mixed refrigerant, adding it in gas form may cause the refrigerant composition to change, preventing normal operation.
- Before charging, check whether the refrigerant cylinder is equipped with a siphon tube or not (the cylinder should be marked with "liquid filling siphon attached" or something similar).
-

Charge the liquid refrigerant with the cylinder in upright position.

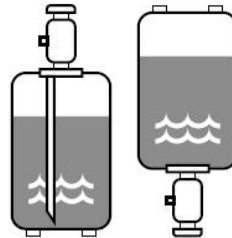

Charge the liquid refrigerant with the cylinder in up-side-down position.

- Be sure to use tools exclusively for R410A to ensure required pressure resistance and to prevent foreign materials from mixing into the system. NB Glasses & Gloves to be worn

Pre-operation checks

Checks before initial start-up

 SWITCH 'OFF' THE POWER SUPPLY BEFORE MAKING ANY CONNECTIONS.

After the installation of the unit, check the following before switching on the circuit breaker:

1. Field wiring
Make sure that the field wiring between the local supply panel and indoor unit, outdoor unit and indoor unit, indoor unit and domestic hot water tank has been carried out according to the instructions, according to the wiring diagrams and according to European and national regulations.
2. Fuses or protection devices
Check that the fuses or the locally installed protection devices are of the size and type specified. Make sure that neither a fuse nor a protection device has been bypassed.
3. Earth wiring
Make sure that the earth wires have been connected properly and that the earth terminals are tightened.
4. Internal wiring
Visually check the switch box on loose connections or damaged electrical components.
5. Fixation
Check that the unit is properly fixed, to avoid abnormal noises and vibrations when on start up.
6. Damaged equipment
Check the inside of the unit on damaged components or squeezed pipes.

7. Refrigerant leakage
Check the inside of the unit on refrigerant leakage. If there is a refrigerant leak, call your local dealer.
8. Power supply voltage
Check the power supply voltage on the local supply panel. The voltage must correspond to the voltage on the identification label of the unit.
9. Air purge valve
Make sure the air purge valve is open (at least 2 turns).
10. Pressure relief valve
Check if the backup heater vessel is completely filled with water by operating the pressure relief valve. It should purge water instead of air.

 OPERATING THE SYSTEM WITH THE BACKUP HEATER VESSEL NOT COMPLETELY FILLED WITH WATER WILL DAMAGE THE BACKUP HEATER!

11. Shut-off valves
Make sure that the shut-off valves are correctly installed and fully open.

 OPERATING THE SYSTEM WITH CLOSED VALVES WILL DAMAGE THE PUMP!

Pump down operation

In order to protect the environment, be sure to pump down when relocating or disposing of the unit. The pump down operation will extract all refrigerant from the piping into the outdoor unit.

1. Remove the valve lid from liquid stop valve and gas stop valve.
2. Carry out the forced cooling operation.
3. After 5 to 10 minutes (after only 1 or 2 minutes in case of very low ambient temperatures ($<-10^{\circ}\text{C}$)), close the liquid stop valve with a hexagonal wrench.
4. After 2-3 minutes, close the gas stop valve and stop cooling operation.

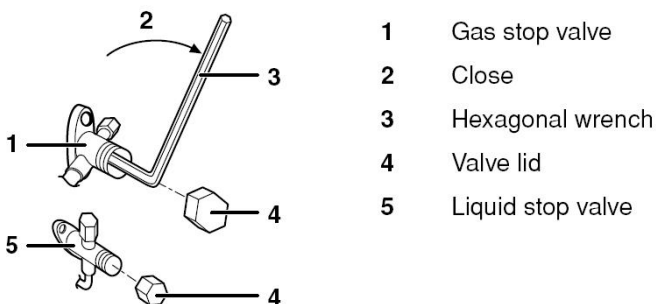

After the initial installation the system needs to be commissioned this document will explain & show how to set up and commission an air to water heat pump.

Stage 1 check that the system wiring is complete and connected properly before switching on the power to the indoor and outdoor unit.

Ensuring that the isolators are switched off at this point and all cables are secure and all terminals are tight and there are no bare ends exposed.

Stage 2 pipe work before commissioning the system and turning the power on you must ensure that the system has no leaks and that the correct charge is in the system if you are not the installation engineer please ensure that the pre –commissioning sheet is completed

Stage 3 switch On the power and set up the LCD controller on the indoor unit.



Versol Poland | Versol Italy | Versol UK | Versol USA | Versol Middle East | Versol India

