



INSTRUCTIONS BOOKLET
FOR INSTALLATION, USE AND MAINTENANCE

**VERSOPUMP - AIR SOURCE
HEAT PUMP MONOBLOCK DC
INVERTER SERIES R410A**



Installation & User Manual

VERSOPUMP - AIR SOURCE HEAT PUMP MONOBLOCK DC INVERTER SERIES R410A

Thank you very much for purchasing our products.
Before using your unit, please read this manual carefully and keep it for future reference.

CONTENT

Information	3
Packing list	4
Required tools for installation	4
Precautions	5
Wires specifications	7
Water pipe specifications	7
Heating operating range	7
Dimensions (Unit: mm)	9
KD-110C/BP	9
KD-180C/BP	9
KD-270C/BP	10
Wiring sketch	11
Electrical data	11
Water pipe connection	12
Water affusion	12
Rated water flow rate	13
Unit installation	13
1. Location requirement	13
4. Trial running	15
1. Wires connection	15
2. Fuse or RCCB	15
3. Grounding wire	15
4. Internal wires	15
5. Unit fixing	15
6. Unit detecting	15
7. Refrigerant leakage	15
10. Relief valve	16
Controller	16
1. Controller display	16
2. Wired controller interface description	17
3. Wire Controller Function Introduction	18
3.1 WIFI setting	19
3.2. Screen setting	19
3.3. Time setting	20
3.4. Timing setting	20
3.5. Factory setting	21
3.5.1 Fault Query	22
3.5.2 Parameter Query	22
3.5.3. Operation data query	23
3.5.4 Other setting	24
4. Error Code Table	25
Smart Life WIFI connection	28

Information



Before install and use the product, please carefully read this manual.

Please keep this manual for future reference.



Please ensure that the unit is installed by a qualified person. If you have any questions, please contact with the dealers or customer service centers.



Before shutting off the system for a long time, please do not shut off the power supply. If shut off the power supply, the protection devices of the heat pump unit (e.g. anti-freezing) cannot be triggered.

The heat pump unit should be installed outside, and please ensure enough air ventilation volume around the unit. The unit can be connected with some terminals, including fan coil units, floor heating and low temperature radiators.

Packing list

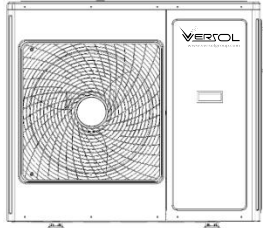
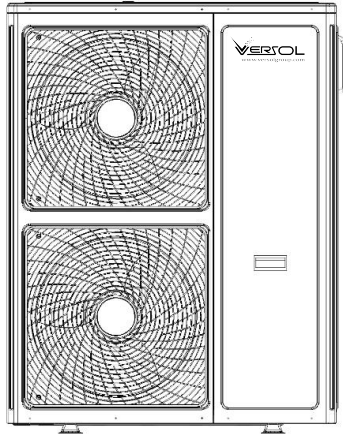
Items	Shape	Quantity	Note
This manual	-----	1	\
Unit		1	KD-110C/BP: RH11-H
		1	KD-180C/BP: RH18-H KD-270C/BP: RH27-H

Required tools for installation

No.	Tools
1	Masonry drills
2	Levelness detector
3	Water pipe beader
4	A tape measure
5	Torque spanner
6	Water pipe cutter
7	Socket set

No.	Tools
8	Screw driver
9	Wire stripper
10	Bow-saw
11	Tapper
12	Adjustable spanner
13	protective equipment (e.g., gloves, classes)

Precautions



Important information

To prevent injury to the users or other people and property damage, the following instructions must be followed. Incorrect operation due to ignoring of the instructions may cause harm or damage.

Please install the product according to local technical standard or regular. Please check the voltage and frequency of the power supply before installation the protection.

The power wires and the grounding wire must be connected the suitable terminals. Each product should be connected with the independent switch of power supply. The following measures for safety should be noticed:

- Before the installation of the product, please carefully read the warnings in this manual.
- Please carefully read the details of the warning in the manual, including the details about the safety point.
- After read the manual, please keep this manual for future reference.



WARNING

- Ensure the installation of the product is reliable.
If the installation of the unit is unstable or reliable, it will be injure the people or make property loss. The bearing weight of the installation foundation is more than 20g/mm².
When the unit is installed in a closed space or limited space, please consider the enough area of the space and enough air ventilation volume to avoid the asphyxia of people or animal.

- Use the power supply wires which are matched with the current of the unit. And the terminals connected the power supply wires and the grounding wire must be fully fastened and regularly checked, in case to become flexible.
- Incorrect wires connection can cause fire. Please strictly connect the wires refer the wiring label in the unit.
- Please use correct materials or specified materials.
If use incorrect materials or specified materials, it will cause fire, electric shock, or unit falling.
- The earthing pole of socket must be grounded well. If there is not the grounded wire from the power supply, please do not connect the unit with the power supply.
- Ask qualified person for installing, relocating, repairing and maintaining the unit.
Improper installing, relocating repairing and maintaining may result in water leakage, electric shock or fire.
- Do not operate the unit with a wet hand; otherwise an electric shock may be caused.
- Do not put the power supply wires of the unit near the other heater or other home appliance. It may be result in fire or electric shock.
- Do not let water enter the electrical components of the unit. It may be cause fire, electric shock and unit damage.
- Never use a flammable spray such as hair spray, lacquer or paint near the unit. It may cause a fire or explosion.
- Please following the manual, connect the water pipe and drainage pipe.
- The water will be leaked because of the connecting defects of the water pipe. Please repair it to avoid get the furniture wet and damage.
- When the power supply is switch on, do not clean the unit. After switch off the power supply, clean the unit. Otherwise, it will result in injure by high speed running fan or electric shock.
- When the running unit have problem or there is some smell, please stop the unit, and switch off the power supply; otherwise it may be result in electric shock or fire.
- During the installation of the unit, please take care of the heater-exchanger coil, and it will cut people finger or other skins.
- After the installation and repairing of the unit, please detect the leakage of the refrigerant. If the unit without enough refrigerant, the unit cannot run normally.
- Please install the unit at a horizontal foundation to avoid produce the abnormal noise and vibration.
- Do not insert fingers into the fan and air side heat-exchanger. When the fan is rotating at high speed, it will cause injury.
- The appliance is not intended for use by young children or infirm persons without supervision. Young children should be supervised to ensure that they do not play with the appliance.

- If the power supply cord is damaged, the cord must be replaced by the manufacturer or the service agent or a similarly qualified person.

Wires specifications

Model	Power supply wires	Signal wires (Controller)
KD-110C/BP	6mm ² (3-cord)	0.75mm ² ×4 (Shielded wire)
KD-180C/BP	10mm ² (3-cord)	
KD-270C/BP	10mm ² (5-cord)	

Notes:

The distance between power supply wires and signal wires should be kept at least 300mm.

Water pipe specifications

Model	Entering/leaving water pipe (Internal thread)	Water pipe
KD-110C/BP	3/4"	≥1"
KD-180C/BP	1"	≥5/4"
KD-270C/BP	1"	≥5/4"

Heating operating range

Outdoor ambient temperature	Entering water temperature
-30°C to 43°C	10°C to 55°C

Water system sketch

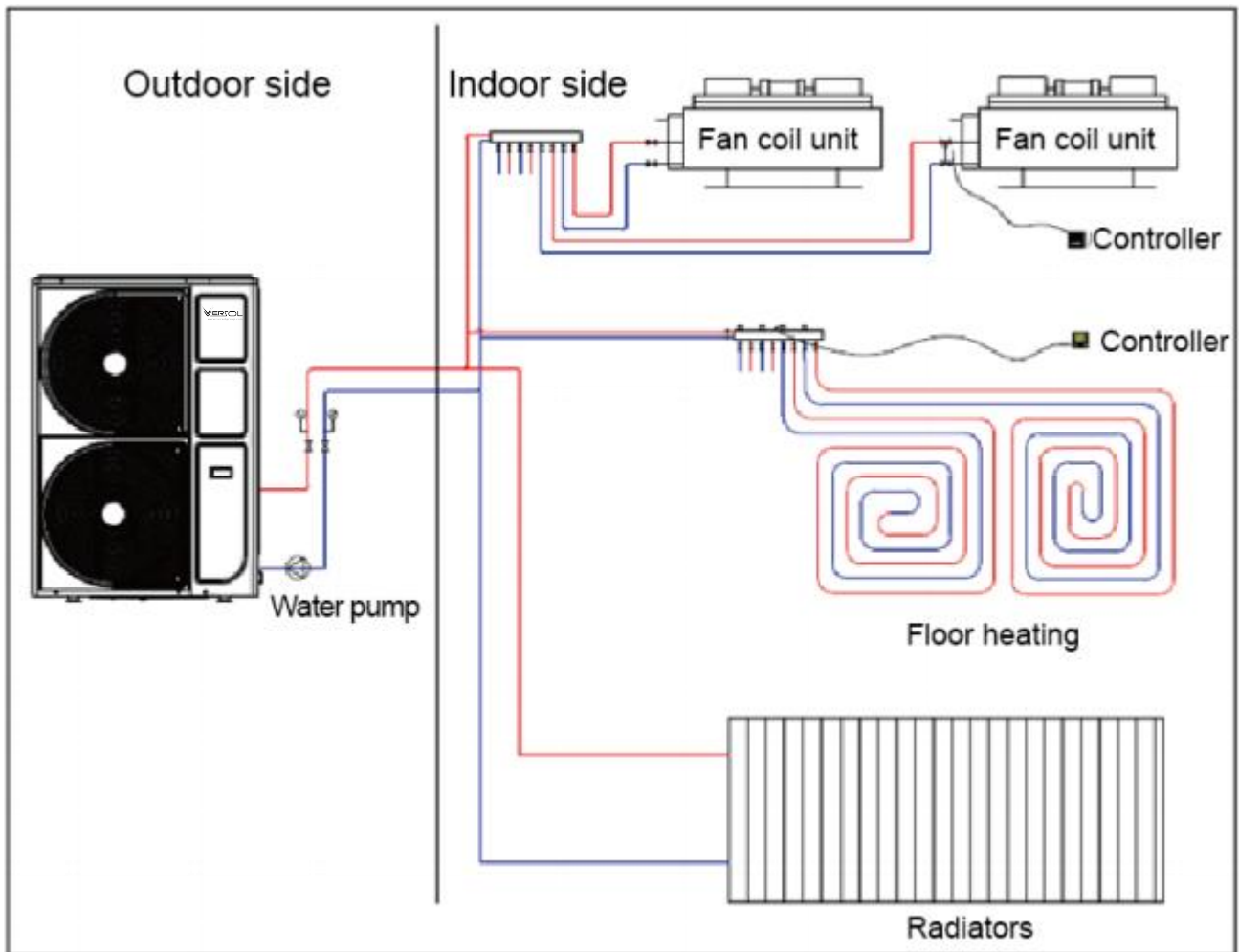

Notes:

1. During the winter, it is strictly prohibited to switch off the power supply for anti-freezing function of the unit.
2. When the unit is not used for a long period, please discharge the stored water in the unit.
3. After a long period, re-use the unit. Please follow the steps to check the water pump:
 - a. Open the air-vent of the water pump.
 - b. Check whether the rotator of the water pump is rotated normally by screwdriver.
 - c. If the rotation is not smooth or normal, please rotate the rotator by screwdriver till it can rotate smoothly.

Dimensions (Unit: mm)

KD-110C/BP

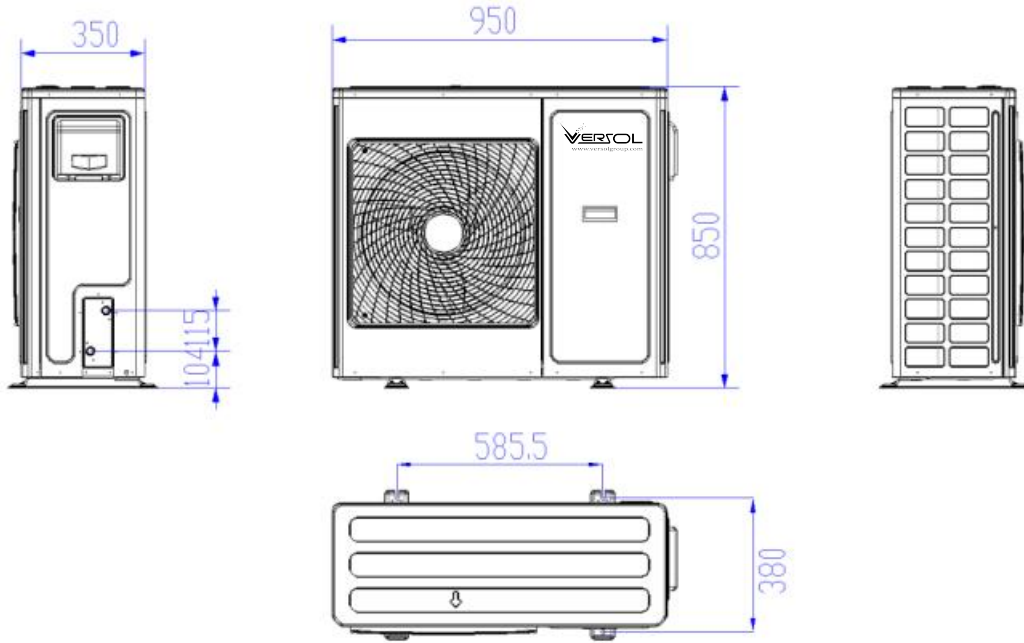

KD-180C/BP

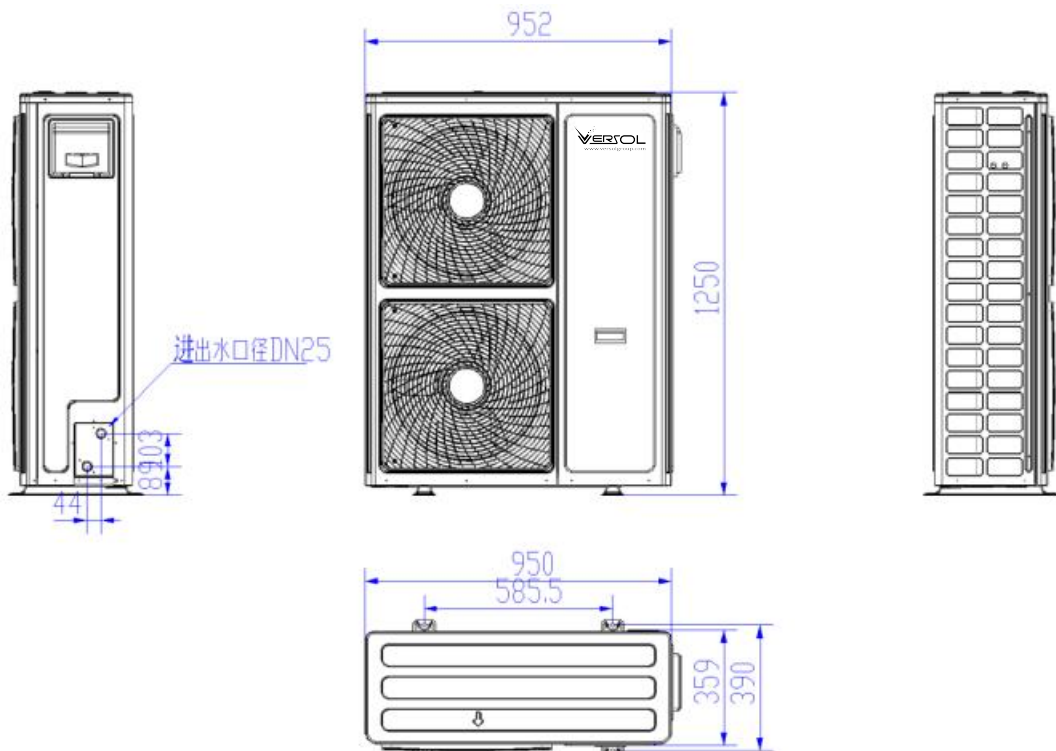

KD-270C/BP

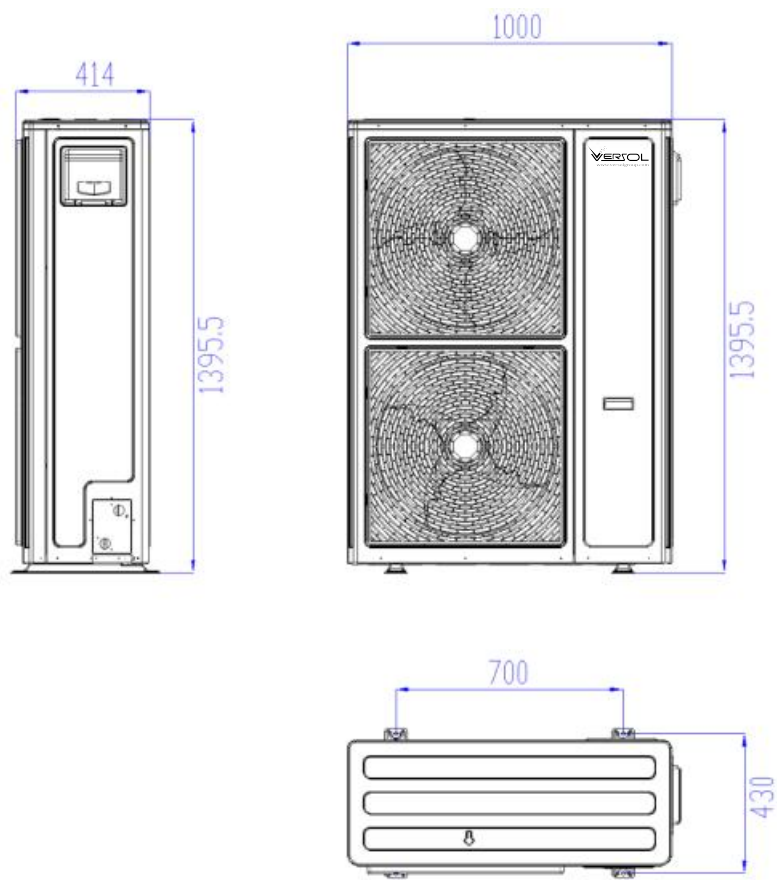

Wiring sketch

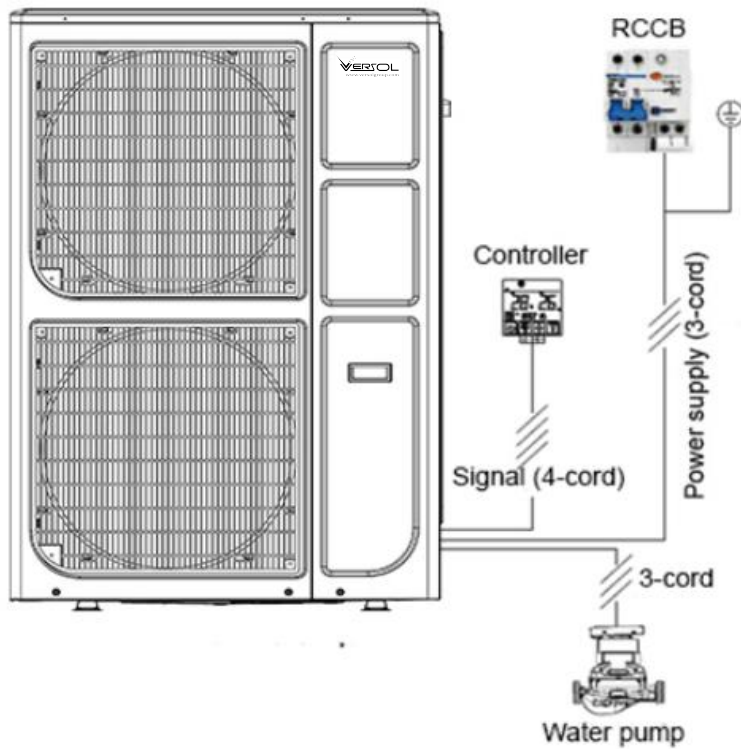

Notes:

RCCB: Residual Current operated Circuit-breaker.

Electrical data

Model		KD-110C/BP	KD-180C/BP	KD-270C/BP*
Heat pump unit	Input	4400W	6600W	11200W*
	Current	20A	30A	20A*
External electric heater	Input	≤3000W	≤3000W	≤3000W*
	Current	≤13.6A	≤13.6A	≤13.6A*
Total Max. current		20A+13.6A	30A+13.6A	20A+13.6A*
Wires	Diameter 1	6mm ²	/	/*
	Diameter 2	10mm ²	10mm ²	10mm ² *

Notes:

Diameter 1: The unit without external electrical heater.

Diameter 2: The unit with electrical heater.

***KD-270C/BP only with signal for electric heater.**

WARNING

- During the wiring connection, please switch off the power supply.
- Wiring connection must be conducted by the professional technicians according to the labelling on the circuit diagram.
- All the wiring connection should comply with local electric standard.
- The power supply of the unit should be an independent circuit. Do not connect the power supply which is already other electric appliance.
- The unit must be provided with grounding wires, which are not allowed to be connected with the grounding wires of gas fuel pipelines, water pipelines, lightning conductors or telephones. Improper grounding connection may cause electric shock, so please check whether the grounding connection of the unit is firm or not frequently.
- Set the electric leakage protector (RCCB) according to the relevant electric technical stands of the national.

Water pipe connection

Before the connection, please check:

- Max. water pressure is less than 10bar.
- There are not valves of entering and leaving water. To convenient maintenance and repairing, please fix valves of entering and leaving water. The location of valves should be easy to operate.
- In low positions of the water system should be provided with drainage ports to drain water in the system completely.
- All high positions should be supplied with discharge valve to facilitate expelling air from the pipe line.
- All the components of the water pipe system should be bearing the water pressure.

WARNING

- If the 3-way motor-driven valve is adopted, please confirm the switch time of the valve should be less than 20 seconds.

Water affusion

1. The water replenishing valve should be connected with water supply pipe.
2. Please confirm that the air discharge valve is open (at least 2 turns).
3. Stop water affusion till the water pressure of the water line system reaches 2bar.

4. If the auxiliary electric heater is fixed in the water line system, please check the tank of the vessel of the heater is full of water. Please open the pressure relief valve, and check whether the water flows out.



NOTICE

- First water affusion, the air in water line system may be completely discharged out. After the unit trial running for 1 hour, the air will be automatically discharged out by discharge valve. Then, some water also should be injected to the water line system.
- The pressure valve through water pressure gauge relates to the temperature of water. More high the water temperature, more high the water pressure.
- The water pressure of the water line system must keep above 0.3bar to avoid that air enter the water circuit.
- Extra water can be flowed out through the relief valve.
- The quality of water must comply with EU standard (98/83EC).

Rated water flow rate

KD-110C/BP	2.0m ³ /h
KD-180C/BP	2.5m ³ /h
KD-270C/BP	3.0m ³ /h

Unit installation

1. Location requirement

- a. The unit should be installed on the solid place which can bear the unit weight and running vibration.
- b. The unit should be installed on the place where the operation noise and air flow expelled shall not affect neighbors.
- c. Do not install the unit near the bedroom to avoid the effect of the unit running noise.
- d. Enough space for installation and maintenance should be preserved.
- e. The air inlet and outlet should be free from obstacles.
- f. No flammable gas is leaked nearby.
- g. The power supply cable should keep at least 3 meters between the TV and other audio-visual equipment.
- h. If the unit is stalled near seaside or other place where the air contains much salt, the unit life will be shortening.
- i. When the unit is under defrosting mode, the water will flow out from the unit chassis. So please do not put the thing which belongs to dry storage under the unit.

j. Keep some measures to avoid the unit become a habitat by the birds or other animal.

2. Space requirement

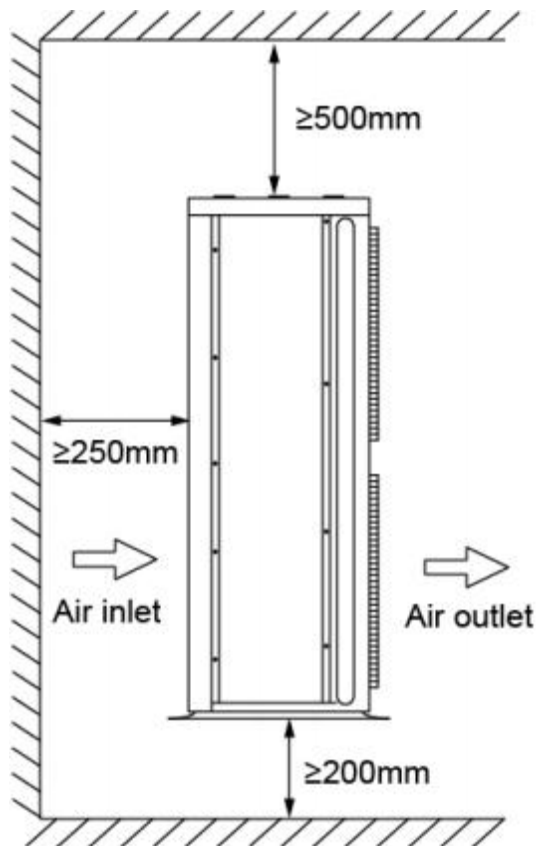
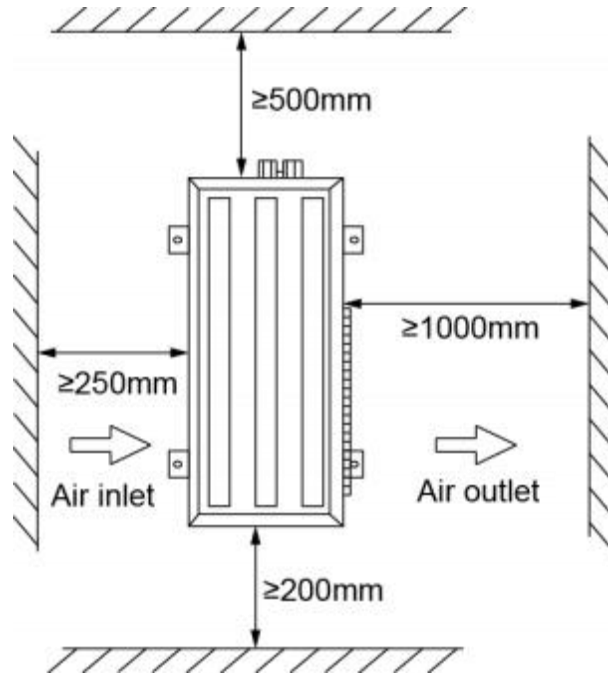

3. Fixing the unit

Please select the proper location, begin to install the unit.

- a. Confirm whether the selected location is flat and solid.
- b. Please prepare 4 set of screw, nut and spring.
- c. According to the chassis of the unit, refer to the following figure to fix the unit.

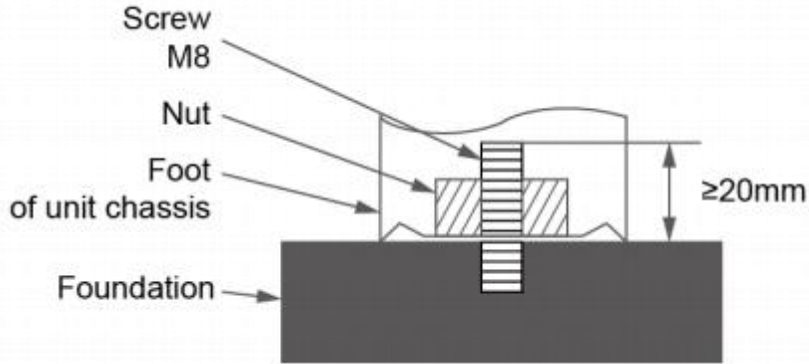

4. Trial running

 Please switch off the power supply.

Before connect the wires between RCCB and the unit, please check the following items:

1. Wires connection
Please ensure the wires connection between the unit, controller and other devices should comply with the local electric standard or regular.
2. Fuse or RCCB
Check the fuse or RCCB is matched with the unit electrical data.
3. Grounding wire
Please check whether the connection of grounding wires is well and tight.
4. Internal wires
Check whether all the electrical components are well.
5. Unit fixing
Check whether the unit is fixed well to avoid the noise and vibration caused by unit operating.
6. Unit detecting
Check whether the pipe including refrigerant and water pipes become deformation and whether some components inside the unit are damage.
7. Refrigerant leakage
Please check whether the refrigerant is leakage.
8. Power supply

Check whether the voltage of power supply conforms to the rated voltage showed in unit nameplate.

9. Air discharge

Please ensure the air discharge valve is open (at least 2 turns).

10. Relief valve

Please check whether the relief valve of auxiliary electric heater is open, and whether the vessel of electric heater is full of water.

 If the vessel of the auxiliary electric heater is not full of water, the electrical heater will be damaged.

 Please check whether all the valves in water line system are open or not. If the valve is closed, the water pump in the water line system will be damage.

Controller

1. Controller display

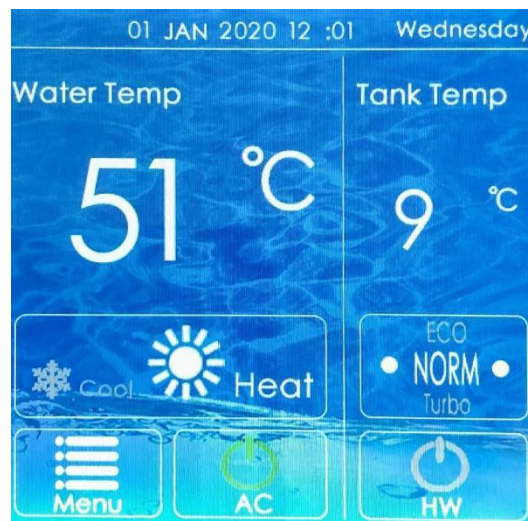

Figure 1 Diagram of Wired Controller

2. Wired controller interface description



Figure 2 Main interface description

Table 1 Description of the main interface of the wired controller

No.	Icon name	Meaning
1	WIFI display	There is no display here when the WIFI is not connected; this icon is displayed when the WIFI is successfully connected.
2	Time indication area	display time.
3	Heating or Cooling water temperature	Display the current space heating or cooling temperature; touch the number to display the "set temperature and plus and minus symbols", click plus or minus to set to the target temperature (the temperature setting is only valid under the power-on condition).
4	Hot water temperature	Display the current water tank temperature; touch the number to display the "set temperature and plus and minus symbols", click plus or minus to set to the target temperature (the temperature setting is only valid under the power-on condition).
5	Mode selection	1. The sun icon is the heating mode; the sun icon is lit to set the heating mode (can be set only under the power-on condition). 2. The snowflake

		icon is the cooling mode; the snowflake icon is lit to set the cooling mode (can be set only under the power-on condition).
6	Functional mode	The unit defaults to "NORM" mode, click this area to switch to other modes. (Currently the unit does not support other modes) 1.NORM: Standard mode, the unit runs in normal state; 2. ECO: Energy-saving mode, the unit operates with reduced power consumption; 3.Turbo: Strong mode, the unit runs at the maximum power.
7	menu	Click this icon to enter the menu setting interface.
8	Hot water side on/off	The icon shows bright green to indicate that the hot water side is turned on, and gray indicates that the hot water side is turned off. Touch to switch the on/off state.
9	Heating or Cooling on/off	The icon shows bright green to indicate that the space heating & cooling side is turned on, and gray indicates that the space heating & cooling side is turned off. Touch it to switch the on/off state. .

3. Wire Controller Function Introduction

The menu interface is divided into WiFi settings, Screen settings, Time settings, Schedule, Sound settings (this function is temporarily canceled), and Factory settings 6 major setting sections, as shown in Figure 3:



Figure 3 Menu interface

3.1 WIFI setting

Click the "WiFi Settings" icon on the menu interface to enter the WIFI connection settings. Click "confirm WiFi reset" to reset the WiFi, and then open the corresponding APP on the mobile phone. After the matching is successful, you can control the air conditioner in the APP. When you have already connected to the APP, click "WiFi is not reset" to choose not to reset the WiFi, and then match it on the

mobile APP. Click the "" icon to return to the menu interface, and click

the "" icon to return to the main interface



Figure 4. WIFI setting interface

3.2. Screen setting

Click "Screen Settings" on the menu interface to enter the screen settings interface. ① The language setting defaults to "English", click "Chinese" to switch to Chinese; ② The default backlight time is 1 minute, the selection range is

1min~30min, press and hold the small dot on the backlight time progress bar and drag to adjust the length of the backlight time.



Figure 5. Screen setting interface

3.3. Time setting

On the menu interface, click the time setting frame area of "Time Setting" to enter the time setting interface. As shown in Figure 6, the time setting interface is year, month, day, hour and minute from left to right, click the "+" and "-" icons in the frame area to adjust to the corresponding time.

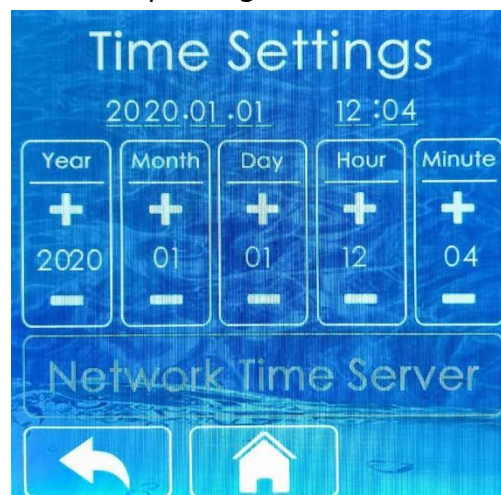

Figure 6. Time setting interface

3.4. Timing setting

Click "Schedule" on the menu interface to enter the schedule setting interface.

① The timing function has three sets of timing periods to choose from, as shown in Figure 7, click the green dot to enable the timing, and click the grey dot to close the timing.

② Click "Timer 1" to enter the timing adjustment interface, adjust the "Turn ON time" to 7 o'clock and the "Turn OFF time" to 8 o'clock, then the air conditioner runs at 7 o'clock and runs to 8 o'clock, click the air conditioning mode selection icon, the green cooling is cooling Mode/Red icon is the heating mode, the hot water icon is red, the hot water is enabled, and the gray is the hot water is not enabled. After the setting is completed, save and exit. "Timer 2" and "Timer 3" are the same as above. As shown in Figure 8, the air conditioner is turned on at 7 o'clock for cooling at 20 degrees and hot water at 50 degrees, and it runs to 8 o'clock and shuts down.

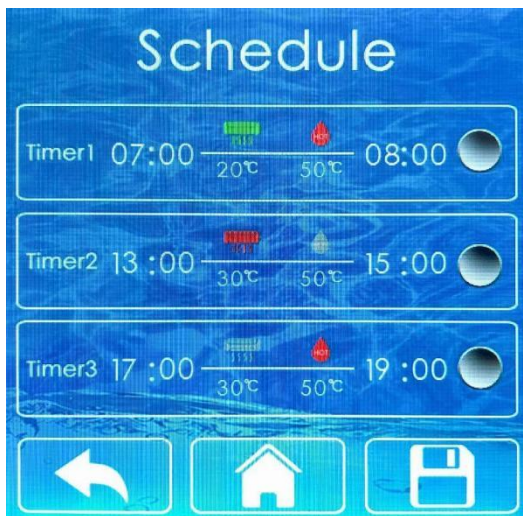

Figure 7 Timing interface



Figure 8 Timing adjustment interface

3.5. Factory setting

On the menu interface, click "Factory Setting" to enter the factory parameter setting interface (note: this function needs to be operated under the guidance of professionals). To enter the factory setting interface, you need to enter the password first, click the "Password Enter" field to enter the three-digit password

(initial password 123), click "Login" to confirm the password, if the password is correct, enter the factory setting interface.



Figure 9 Password input interface



Figure 10 Factory setting interface

3.5.1 Fault Query

On the factory setting interface, click the "Fault" frame to enter the fault query

interface. Click the  icon to return to the previous factory setting interface,

and click the  icon to return to the main interface.



Figure 11 Fault Query

3.5.2 Parameter Query

On the factory setting interface, click the "Parameter" frame to enter the parameter query interface.

① When the parameters need to be changed during the unit commissioning, it is recommended to check the parameter table and click the small triangles on the left and right of the corresponding parameter value to add or subtract to adjust to the target value. Changes are automatically saved when completed.

② When you click the frame where the up key of the parameter interface is located, the page is turned up, and when you click the frame where the down key is, the page is turned down. You can go back after setting is complete.



Figure 12 Parameters Query

3.5.3. Operation data query

In the factory setting interface, click the "Operations" frame to enter the unit operation data query interface, and you can click the up and down keys to turn the page to query the data.



Figure 13 Operation data query interface

3.5.4 Other setting

In the factory setting interface, when you click the frame area where "Others" is located, it will enter the other interface.

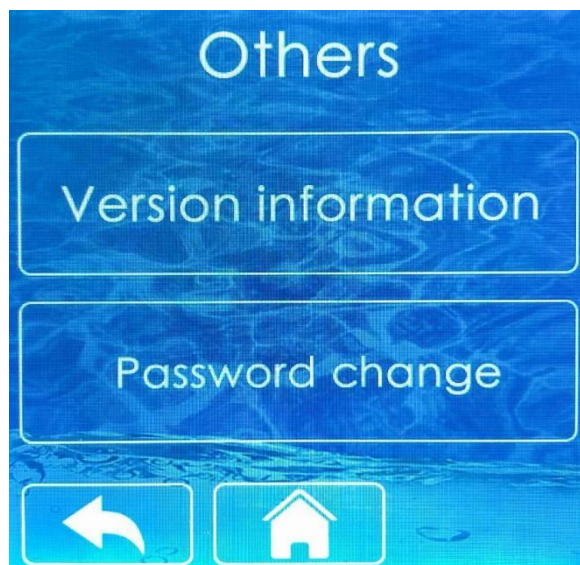

Figure 14 Other setting interface

① In the "Other" interface, click the "Version Information" frame to enter the version information interface, and query the version information of the main control board program and the version information of the wire controller program.

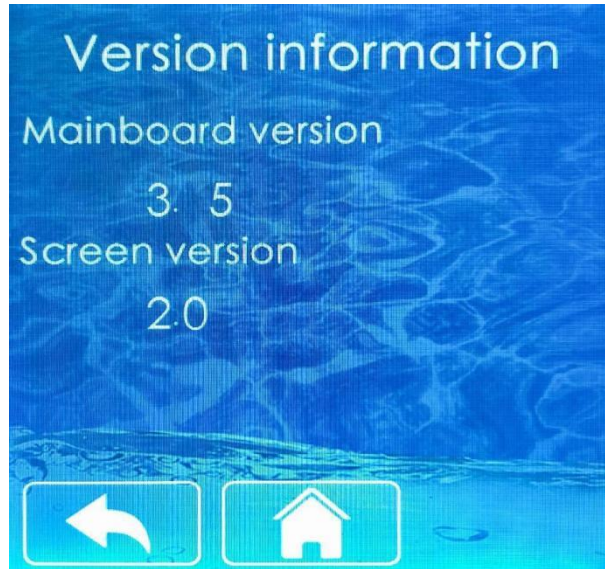

Figure 15 Version information

② In the "Other" interface, click the area where the "Password Change" frame is located to enter the password change interface. Enter the same new password in the "New Password" field and "Confirm Password" field and save it.



Figure 16 Password change interface

4. Error Code Table

Fault code	Fault name	Failure analysis	Solution
F 02	Return water temperature sensor failure	1. The sensor connection line is open or short-circuited; 2. Sensor failure; 3. Main control board failure;	1. Repair the connecting cable and plug or replace the sensor; 2. Replace the motherboard;
F 04	Outlet water temperature sensor failure		
F 03	Liquid pipe temperature sensor failure		
F 01	Water tank temperature sensor failure		

A 04	Exhaust temperature sensor failure		
A 07	Gas return temperature sensor failure		
A 02	Defrost temperature sensor failure		
A 01	Ambient temperature sensor failure		
A 08	Coil temperature sensor failure		
F 05	Water flow switch disconnection protection	1. System is short of water 2. Water flow switch failure 3. The system is clogged.	1. Open the valve; 2. Replace the water flow switch; 3. Clean or replace the filter mesh
F 09	Antifreeze switch disconnection protection when cooling	1. Water flow is too low; 2. The heat exchanger is blocked; Y- shaped filter is clogged; 4. The load is too low.	1. If there is a problem with the drain valve, replace it with a new one; 2. Use water or high pressure in the opposite direction Gas blown plate heat exchanger clean up;
F 10	Insufficient water flow protection	1. Water flow is too low; 2. The heat exchanger is blocked; Y- shaped filter is clogged;	1. Clean or replace filter mesh ; 2. Replace high-flow water pump;
A 11	Pd temperature sensor failure (saturation temperature corresponding to the pressure sensor)	Reserved	Reserved
H 03	External unit EEPROM failure	Chip data error	1. Turn off the power and restart
P 06	High pressure switch disconnection protection	1. The water flow is small; 2. High voltage switch failure; 3. The refrigeration system is blocked; 4The electronic expansion valve is locked.	1. Refill water or replace a pump with a larger flow rate and add a booster pump; 2. Replace the high-voltage switch; 3. Replace the filter; 4. Replace the electronic expansion valve.
P 09	Low pressure switch disconnect protection	1. Lack of refrigerant; 2. The refrigeration system is blocked; 3. Beyond the system working scope.	1. Fix the leak and refill the refrigerant 2. Replace the filter 3. It exceeds the system working limit and cannot be enabled .
P 01	High pressure side over pressure protection when cooling	1. The refrigeration system is blocked; 2. Beyond the system working range.	1. It exceeds the system working limit and cannot be enabled .
E 06	Internal and external unit communication failure	Reserved	Reserved
L 12	Main control-drive communication failure	1. The communication cable is broken; 2. Main control board failure; 3. Drive module failure;	1. Replace or repair communication cables; 2. Replace the main control board; 3. Replace the drive module;

L 05	Main control-DC motor power board communication failure	Wiring error or IPM module failure Check for wiring errors, reconnect the cable or replace the IPM module	
C 04	High exhaust temperature protection	1. The system lacks refrigerant; 2. Exhaust temperature sensor temperature drift shift.	1. Repair the leak and refill the refrigerant; 2. Replace the temperature sensor.
C 07	Exhaust overheat degree too low protection	Reserved	Reserved
y 03	External DC fan 1 failure	1. Fan failure or stuck; 2. Main control board failure	1. Check whether the fan is stuck or replace it with a new one; 2. Replace the main control board
J 03	External DC fan 2 failure		
H 05	Four-way valve failure	1. The inlet and outlet water temperature sensors are plugged in backwards; 2. Four-way valve failure; 3. Main control board failure;	1. Correct the mistakes; 2. Try to switch repeatedly to see if it can If the action does not work , replace it; 3. If it is wrong , replace it;
d 09	Driver IPM over temperature protection	Wiring error or IPM module failure Check for wiring errors, reconnect the cable or replace the IPM module	
d 05	Driver input overcurrent protection/phase current overcurrent protection		
d 06	Driver DC bus voltage over and under voltage protection		
d 07	Driver heat sink temperature sensor failure		
d0 1	Driver module protection		
d0 2	Driver module hardware protection		
d0 3	Module software protection		
d0 4	Compressor is not connected		
d1 0	Compressor out of step/or failed to start		

Note:

In the winter heating season, the unit is strictly prohibited from powering off to ensure the normal operation of the unit's antifreeze function. When the unit is not in use for a long time, please drain the water from the system. The product will be subject to change in design specifications, performance and technical parameters, etc., without prior notice, please refer to the product. The final interpretation right belongs to the factory.

Accessories:

Smart Life WIFI connection

This wired controller can be connected to WIFI through the "Smart Life" software to control the unit. Connection steps:

1. First operate the wired controller, click "confirm WIFI reset" in the Wifi settings to reset the WiFi;

2. Download the "Smart Life" software on the mobile phone, turn on the Bluetooth on the mobile phone and connect to WIFI (the software only supports 2.4Ghz WIFI). As shown in Figure 17:

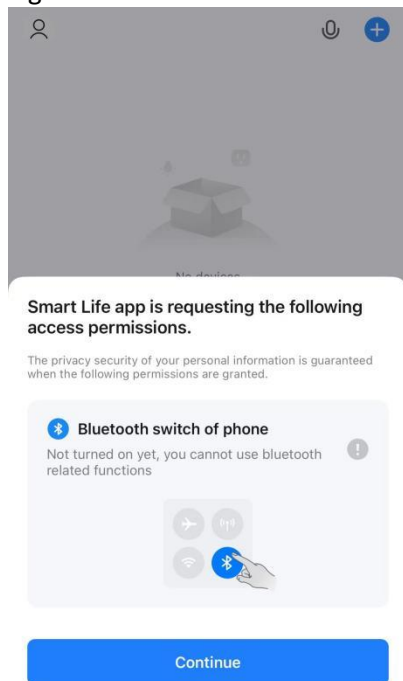

Figure 17. Turn on Bluetooth on your mobile phone

3. Open the "Smart life" software, generally it will prompt to add a device, click to add (as shown in Figure 18); if it cannot be added, you need to manually set it, find "Air Conditioner" in "Add Manually" and click Next, Then enter the WIFI and password that the mobile phone

is connected to. If the connection is successful, you can directly go to the next step.

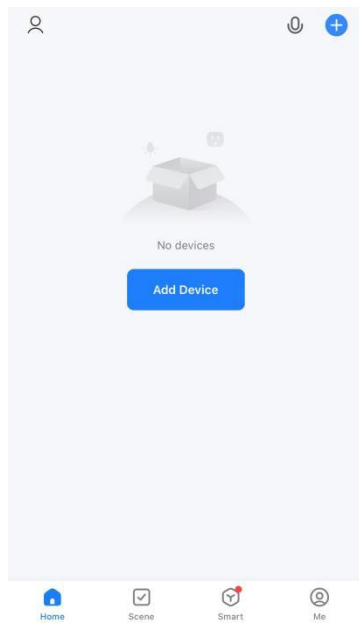

Figure 18. Add device

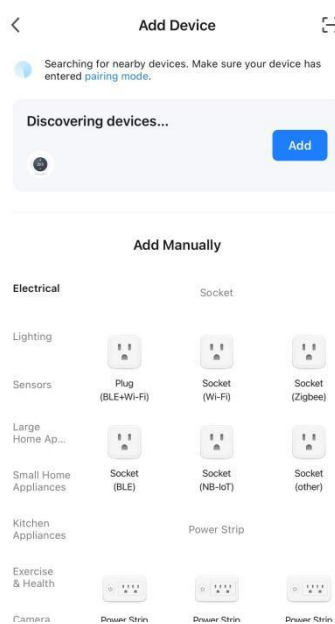

Figure 19. Auto-discover device

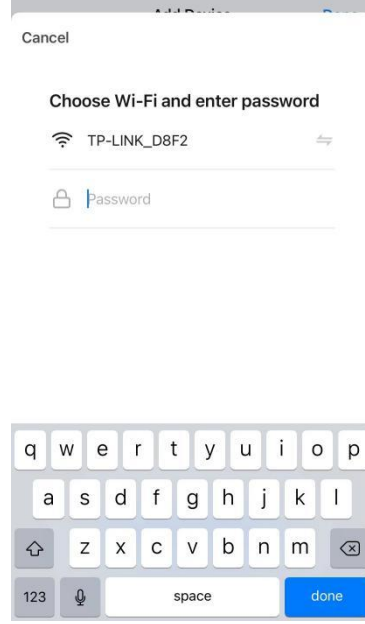

Figure 20. Auto-discover device

4. Click on the successfully added device (as shown in Figure 21) to open the air conditioner control interface (as shown in Figure 22), you can control the on/off of the air conditioner and hot water, control the air conditioner mode, control the set temperature, view the current temperature and other functions on the APP .

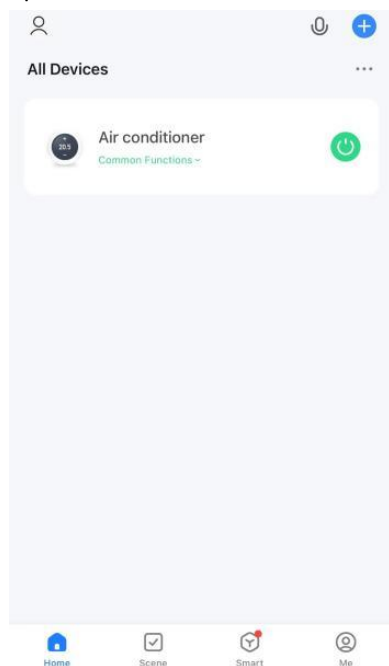

Figure 21. Successfully added device

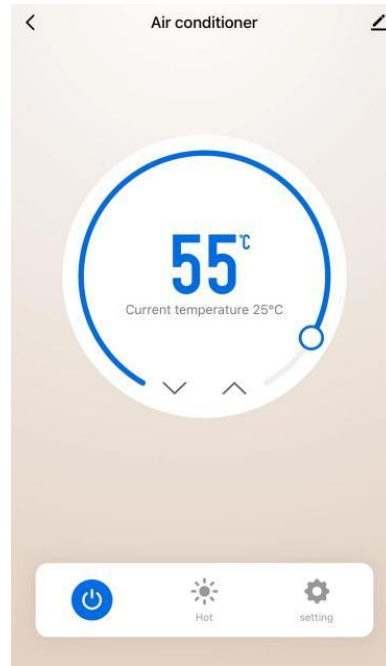

Figure 22. Air conditioner control interface



Versol Poland | Versol Italy | Versol UK | Versol USA | Versol Middle East | Versol India

