



INSTRUCTIONS BOOKLET FOR INSTALLATION, USE AND MAINTENANCE

AIR SOURCE HEAT PUMP



INSTRUCTIONS BOOKLET
FOR INSTALLATION, USE AND MAINTENANCE

AIR SOURCE HEAT PUMP





Dear Customer,

Thank you for choosing an Air Source Heat Pump by VERSOL GROUP.

In your interest and to maintain the highest level of performance and life of your appliance, we recommend that you follow the instructions contained in this booklet and have regular maintenance performed by qualified personnel.

We would like to remind you that failure to follow the instructions contained in this booklet may invalidate the guarantee

This unit should have maintenance regularly. The regular maintenance and cleaning will help the product stability, security, and long-term operation. Clean the dust and dirt inside the unit will also help to improve unit heat transfer efficiency and save energy.

If the unit shut down in long time due to some factors, please be sure to drain off the water in pipeline, to prevent rust or as the low temperature in winter may cause the pipe cracking and system running problem again.

With the constant progress of science and technology, product has constant update and optimization; please pay attention to the latest product information.

CE 0085



CONTENTS

Notes	PAGE-04
Characteristics and Parameters	PAGE-06
Installation Instructions	PAGE-07
Operation Illustrations	PAGE-19
Debugging and Running	PAGE-29
Troubleshooting	PAGE-30
Maintenance	PAGE-32
Warranty services	PAGE-33
General Schematic Drawing and Basic Description	PAGE-36

NOTES

- 1.1. Dear User: Before you install and use this product, please read this manual in detail to avoid the problem of equipment damage, operator injury and property damage etc.
- 1.2. If you have any questions about technology when you read the manual, please inquire the local agent or our company as soon as possible.

 **Warning** Means improper handling will cause serious injury or death.

 **Note** Means improper handling will cause injuries or property damage.

 **Remind** Means make further remind and interpretation to the contents stated

Warning

- Please entrust professional installation, the installation personnel must have the relevant professional knowledge. Prohibited to install it yourself if you are not professional, otherwise, may cause leakage, electric shock, fire and other accidents.
- When the units need to move, repair or reinstall, please entrust dealer or professionals, prohibited to do maintenance or installation yourself if you are not professional, otherwise, can lead to leakage, electric shock, fire and other accidents.
- The unit can't install near the flammable (paint, coating, gasoline, chemical reagent, etc.), in order to prevent fire or explosion.
- Non-professional personnel can not adjust the internal switches, valves, controllers, etc.
- If unfortunately have a fire, the main power supply should be immediately shut down and take the corresponding correct measures to put down the fire.
- Please use the specified capacity of the fuse or overload protector, do not use the iron wire, copper wire instead, otherwise will lead to serious damage or fire to the unit.
- When customers purchase spare parts, choose the specified products of our company, otherwise may cause leakage, electric shock, fire and other accidents.
- During the electrical installation shall comply with the relevant provisions of the state, be sure to consult the electrical wiring diagram.
- Heat pump unit must be reliable grounding, forbid to operate the unit without grounding, it is strictly prohibited to connect ground wire on the zero line or water pipe.
- It is forbidden to put fingers, clubs in heat pump units, don't touch the fan blades to avoid an accident (Children must avoid by all means).



Note

- Confirm whether installed leakage protection switch, must be installed leakage protection switch, otherwise may cause electric shock.
- Correct connection cable. If the cable connection error may damage the electrical components, do not touch the refrigerant exhaust pipe parts with the hand, to prevent burns.
- Do regular maintenance of the unit according to the instruction manual, to ensure the unit running in good condition.
- If the refrigerant leakage, should immediately cut off all the unit's power supply.
- When the fuse fusing repeatedly or leakage protection switch frequently open, should immediately stop running, cut off the power switch manually, and contact the dealer or customer service.
- When choosing to install the heat pump unit, please check whether the corresponding power supply capacity meets the requirements of this unit's power, see details on the nameplate or installation instruction.
- If the unit or water tank is mounted on the roof etc., be sure to take measures against lightning.

CHARACTERISTICS AND PARAMETERS

2.1. Unit features:

◆ System Integration

With built-in international famous brand compressor, super pressure resistance shell condenser, low-noise & big air volume inner rotor fan, etc., to ensure stable operation of the unit.

◆ Safety Integration

Unit has multiple protection features: anti-freezing protection, compressor overheat protection, reverse phase protection, lack of phase protection, high and low pressure protection, overload protection, high temperature protection, water flow protection, time delay protection, etc., to provide water of the project under 100% security.

◆ Energy Saving Integration

Patented independent defrosting flow path, spiral vortex efficient shell and tube heat exchanger, thus could reduce heat loss in winter defrosting, improve air heat exchange efficiency, enhance automatic descaling ability, improve the comprehensive energy efficiency of the unit.

◆ Intelligent Integration

Intelligent operation, power off memory, no need special care, automatic heating, automatic water refilling, free setting of power on/off, could meet water supply of different projects.

2.2. Technical Data

◆ Refer to Catalogue (ET-H).

INSTALLATION INSTRUCTIONS

3.1. Installation Notes:

1).Installation position of the unit is more flexible, choose well ventilated position as priority

2).The installation of the unit must be far away from corrosive substances.

3).Unit needs to have a professional installation, installation must comply with the corresponding provisions of the local government and relevant departments.

4).Installation's base height should be not less than 200 mm, need good unobstructed drainage in installation location.

5).Occasion for special installation requirements please refer to construction contractors or architects or other related professional consultation.

6).The unit can be installed on the ground, roof or in basement but the premises should be sure to have adequate ventilation and meet the demand of heat exchange. Need lightning protection for the whole heat pump system if the heat pump installed on the roof.

7).When the unit is installed on the roof, the roof must have enough strength to support the weight of the unit and related parts, the unit can be placed on the concrete bases or channel steel frame.

8). Don't install the unit where noise and vibration could be a nuisance.

3.2. Build the bases for heat pump:

Concrete bases:

The base is made of concrete, good at shockproof, specific requirements:

- a) The surface of concrete bases should be solid and smooth; load-bearing of support surface should be 2 times of the operation weight of the unit.
- b) When make concrete base, suggested the following treatment: place on the twisted steel which the diameter ≥ 9.5 mm, put two layers of the twisted steel up and down, 10cm distance between the two layers, and banding.
- c) When do concrete bases on the concrete floor, the surface must be kept rough before construction, do cleaning up and supply enough water before constructing.
- d) The concrete base is mixed by ratio of 1:2:4, to be solid, and use the prescriptive size and quantity of anchor bolts according the unit size and weight. The finished base surface should be kept smooth.
- e) Concrete base station surface required waterproofing treatment, drains shall be installed around and the slope should be larger than 0.5° , the slope toward to the drain outlet.
- f) Concrete of base must be dry completely before installing the units.
- g) In order to enable the device quietly operating, to avoid vibration and noise impact the floor between the concrete bases and unit base needs be isolated by shockproof pad.
- h) The unit discharges condensate water - please consider drainage around the bases and install damping device between the bases.

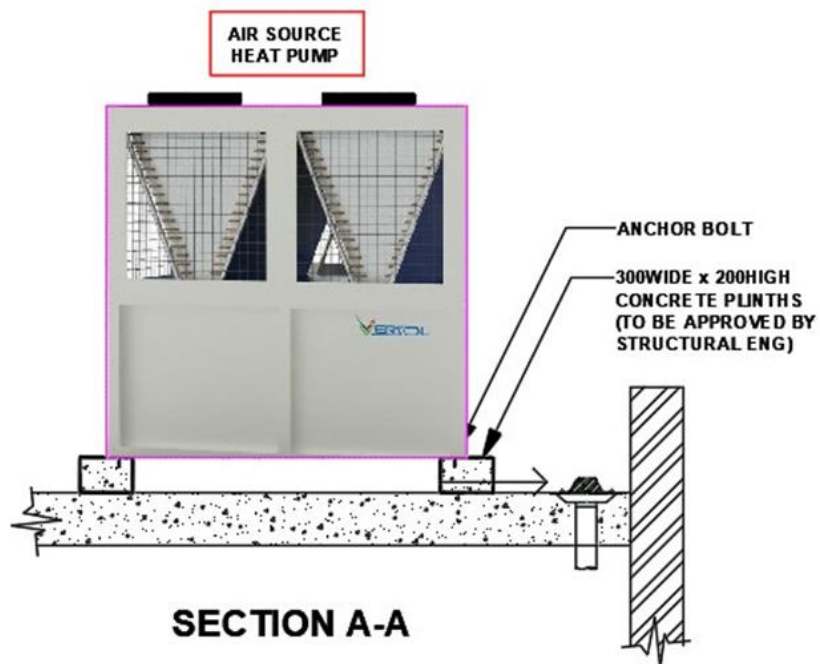
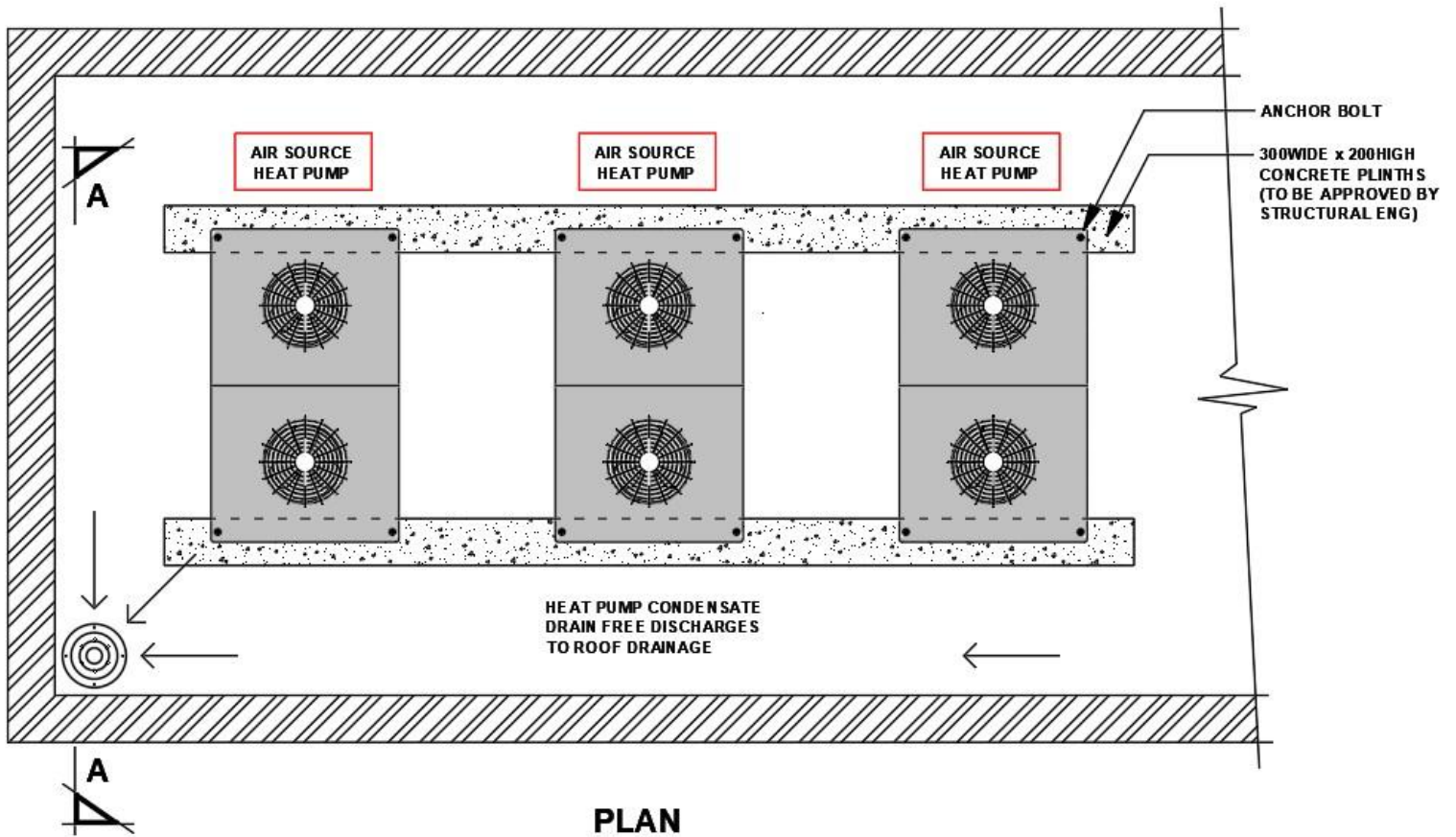

(Picture1)

3.3. Installation space requirements:

3.3.1 Hot spring (Commercial use circulation type)

The above products installation layout reference as shown in (Picture 2) requires the reserved space, When the top side of unit have obstructions reference as shown in (Picture 3) required reserve.

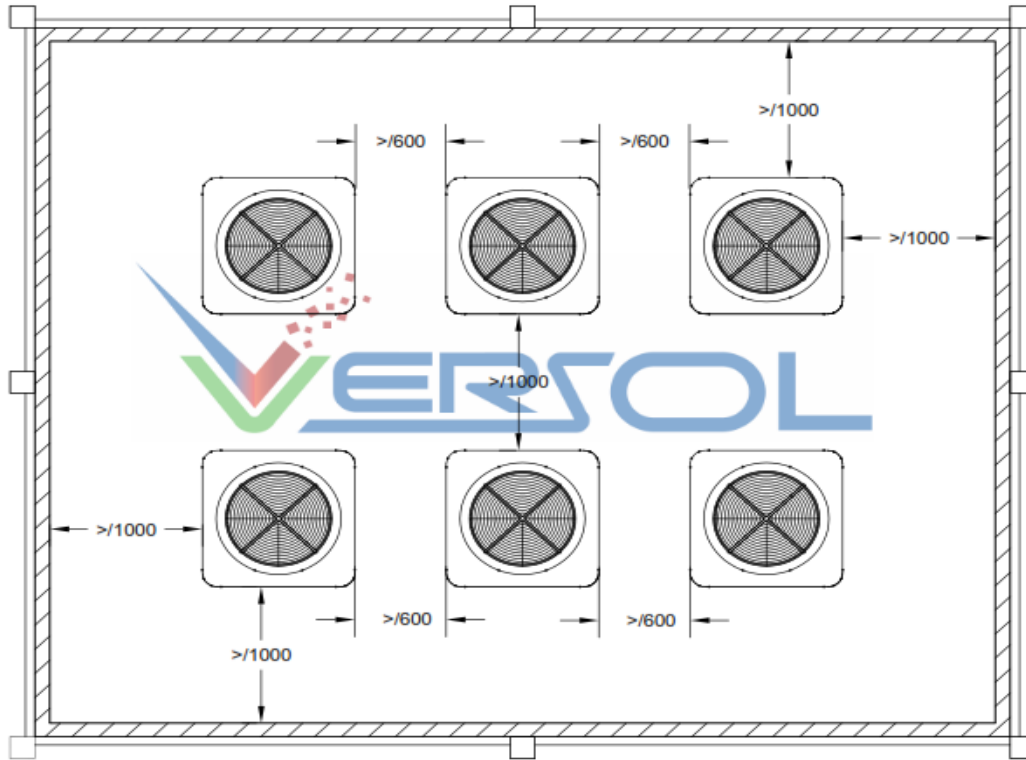

(Picture2)

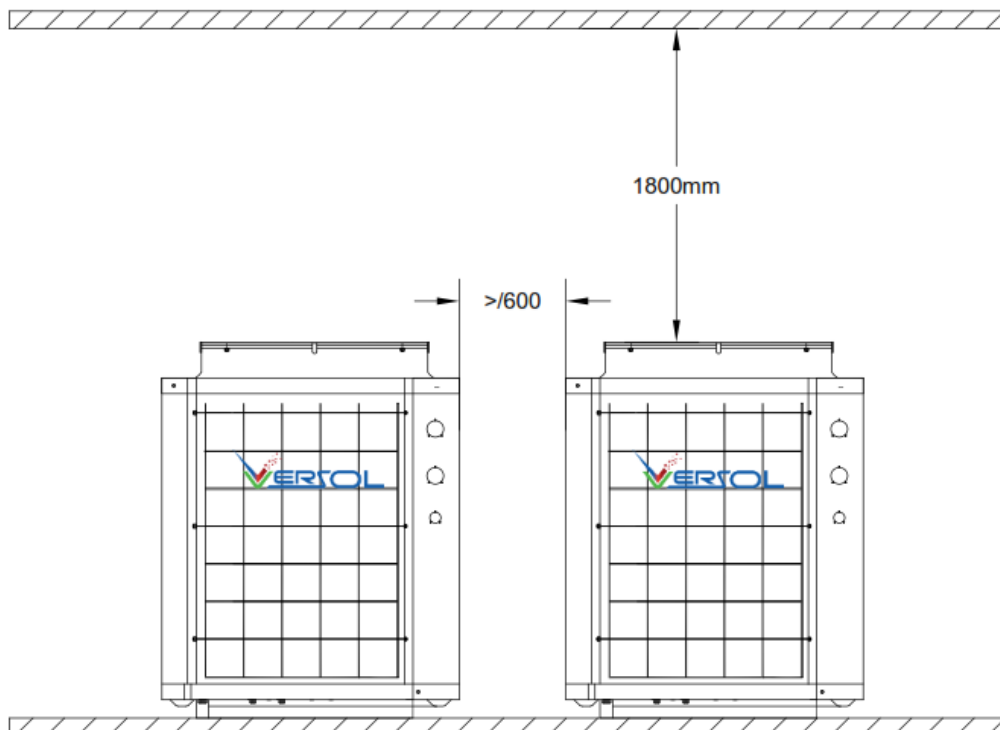

(Picture3)

 **Remind**

- The above diagram for reference only, product appearance may have differences with schematic structure, please refer to our actual product.

 **Note**

- If the unit is installed in the basement, should make sure good ventilation.
- Set aside enough space for unit installation.

3.4. The hoisting:

- 1) Recommended taking 2pcs of steel wire rope ($\geq \Phi 12.5$ mm) to lift the unit, handling process must be careful, to avoid any damage of the unit.
- 2) In order to avoid the surface scratches, deformation, please add protection sheet between the steel wire rope and the heat pump contact surface.
- 3) After hoisting, please remove transportation use plate.
- 4) According to the structure of unit, refer the hoisting pictures (4) (5) (6) for your reference.

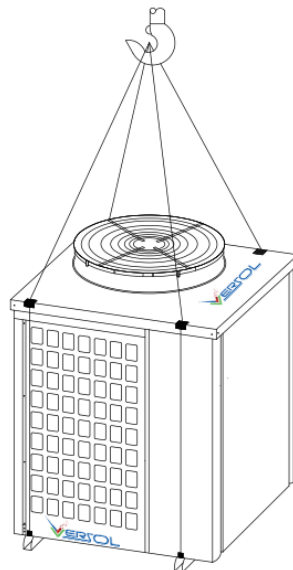

(Picture 4)



(Picture 5)

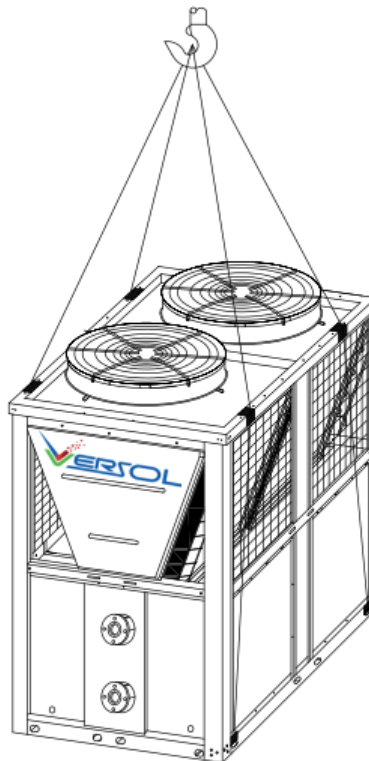

(Picture 6)

Note

- Be sure to pay attention to safety when lifting.
- The hoisting illustration above are for reference only, specific lifting should be according to actual circumstances.

3.5. Pipeline installation:

- 1) Piping system design and construction must conform to the national plumbing pipe design specifications and relevant standards.
- 2) When under DN50, priority to choose PPR pipe, above DN50 (including DN50) choose galvanized pipe.
- 3) The installation process must prevent dust and other debris into the piping system.
- 4) Only install water pipe after the completion of fixing the unit.
- 5) Water inlet and outlet pipe, circulation system water pipe must be packed with thermal insulation material for heat preservation.

When connecting the water input pipe and water output pipe, Must use two spanners, respectively clamped to connect the two parts, to ensure that water input pipe and water output pipe of the unit cannot be turn. As shown in the picture below:

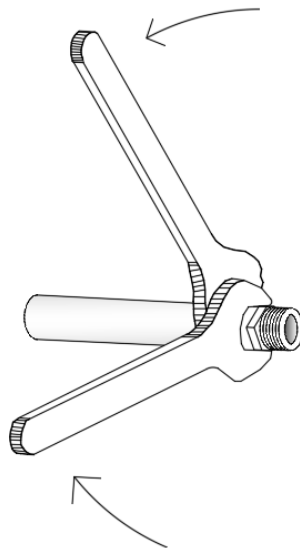

(Picture 7)

3.6. The installation position for water tank

- a. Installation of water pipe and electrical connections is simple for qualified technician.
- b. Supply enough space for installation and maintenance.
- c. The support surface should be flat, must bear the max. weight of the water tank full with water.
- d. Check for any corrosive gas leaks.

3.7. The installation for water level switch, overflow switch & water tank temperature probe:

1) The water level switch must be installed on the top interface of the water tank, and tighten securely.

If cannot use threaded connection to fix the water level switch, use the lifting lug of the water level switch for hanging installation. Do not hang other position of the water level switch for avoiding damage of the water level switch.

- In order to prevent the outflow of the water in the tank, it is necessary to have the overflow outlet and install overflow switch in the water tank, its installation height must be higher than water level switch, lower than the overflow outlet.
- After the installation, please check if the water level switch (high, middle and low water level) is installed correctly, and is running normally.
- Water tank temperature sensor can now be contacted directly with water, therefore must set sensor blind pipe, water tank temperature sensor is installed in the blind pipe.



CALORIFIER CONNECTIONS	
A	PRIMARY RETURN
B	PRIMARY FLOW
C	TEMP GAUGE
D	AIR VENT
E	SECONDARY FLOW
F	SAFETY VALVE
G	SECONDARY RETURN
H	COLD FEED
J	DRAIN
Z	ELECTRIC HEATER

(Picture 8)

Note

• If using other types of water level switch, install it according to the actual situation of the water level switch.

3.8. Pipeline connection:



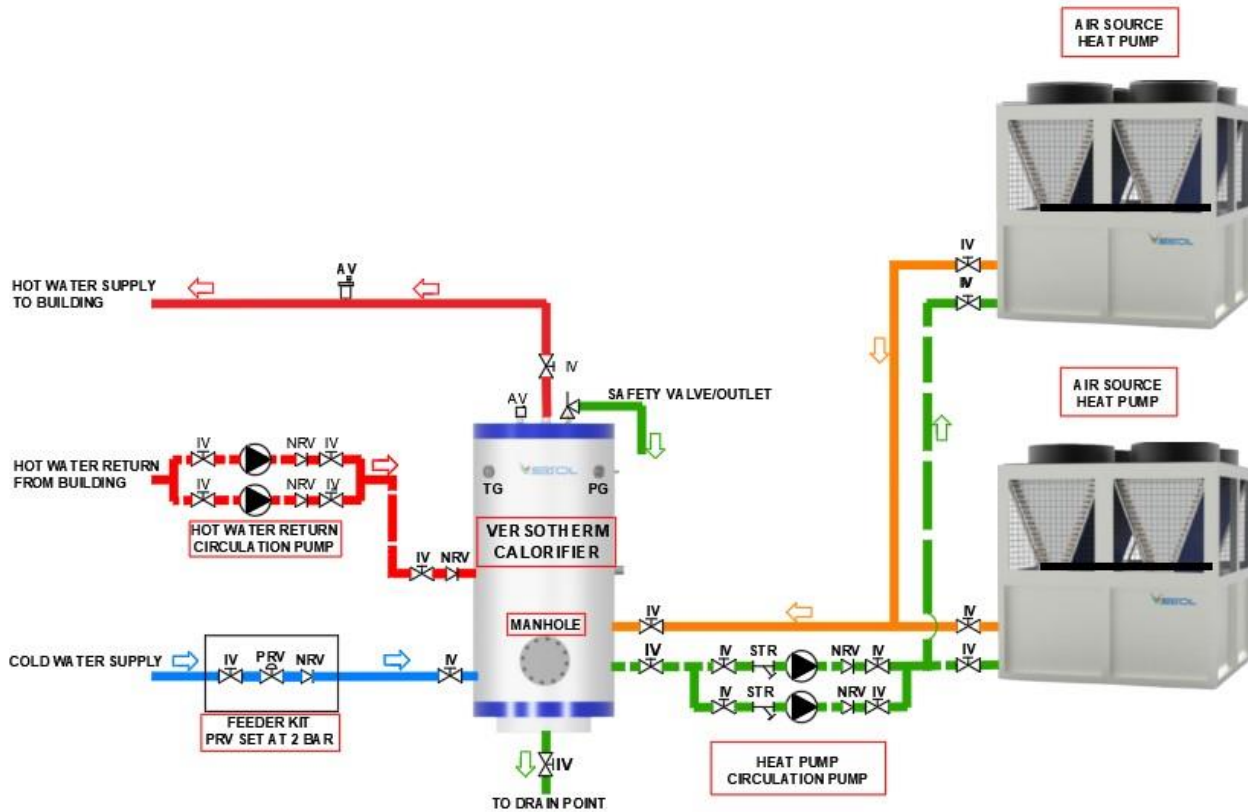













Commercial use circulation type series products pipe connection refers to (Picture 9):



(Picture 9)

Table 2 Symbol Legend

VALVES & PIPEWORK FITTINGS

SYMBOL	NAME	SYMBOL	NAME
	ISOLATING VALVE		PRESSURE GAUGE
	NON-RETURN VALVE		TEMPERATURE GAUGE
	RELIEF VALVE		TEMPERATURE SENSOR
	TWO PORT VALVE		FLEXIBLE CONNECTION
	THREE PORT VALVE		PUMP
	SAFETY VALVE		AUTOMATIC AIR VALVE
	ANGLED SAFETY VALVE		DRAIN COCK
	SOLENOID VALVE		STRAINER

3.9. Installation & selection of water pump:

3.9.1 The design & installation of the water booster pump:

- 1) The design of the system pressure is 0.20 MPa, work pressure range 0.05-0.35 MPa.
- 2) If the water inlet is to be connected to the tap water network, it must be connected to the main tap water supply pipe.

3) When water pressure ≥ 0.40 MPa, must install pressure reducing valve, adjust the water pressure of the unit water inlet to 0.20 MPa;

4) When water pressure < 0.20 MPa, an automatic constant pressure device is required.

5) Rated flow design for automatic constant pressure device:

Rated flow = unit rated water producing quantity \times quantity of units

3.9.2 The design and installation of the hot water circulating pump:

6) Circulating water pump rated head of delivery:

The most unfavorable circulation pipeline $(L1 + L2 + L3 + \dots + Ln) \times$ resistance coefficient + pipeline total local resistance + unit resistance

7) Rated flow of circulating water pump:

Single unit cycle heating rated flow \times quantity of units

**Note**

- When unit cycle heating, specific heat exchange side water flow please refer to performances table.

**Note**

- Hot water circulating pump must use hot water pump; the high temperature bearing capacity of the circulating water pump can not be lower than 80°C.

3.10. Water quality requirements

Products only used for heating sanitary hot water, the hot water be heated must comply the requirements as below table 3:

Table 3 Water quality requirement

Project		Reference value	Tendency		
			Corrosion	Scaling	
Basic items	PH Value pH(25°C)		6.5~8.0	0	0
	Electrical conductivity(25°C)	μS/cm	<800	0	0
	Chloridion Cl ⁻	mg(Cl ⁻)/L	<200	0	
	Sulfate ion SO ²⁻	mg(SO ²⁻)/L	<200	0	
	Acid consumption (pH=4.8)	mg(CaCO ₃)/L	<100		0
	Full hardness	mg(CaCO ₃)/L	<200		0
Other items	Ferrum Fe	mg(Fe)/L	<1.0	0	0
	Sulfur ions S ²⁻	mg(S ²⁻)/L	not allowed	0	
	Ammonium ion NH ⁺	mg(NH ⁺)/L	<1.0	0	
	Silicon chloride SiO ₂	mg(SiO ₂)/L	<50		0

Note: 0 means corrosion or scaling tendency of relevant factors



Note

- When the water quality can not reach the requirements, Equip corresponding water treatment equipment according to the water quality situation.

3.11. Electrical installation:

Electrical installation considerations:

- 1) The unit should use independent power supply, and power supply circuit must be reliable grounding.
- 2) Should have protection measures against electric leakage and short circuit, according to the relevant state regulations on electrical equipment standards.

3) When parallel wiring of high voltage and low voltage, please wire into a separate wire tube, to keep a proper distance, bigger distance if possible.

4) After all wiring completed, please check carefully and make sure no mistakes before connecting to power supply.

3.12. Power wiring requirements:

Comply as per Standard.

3.13. Connect to power supply:

Power wiring refer to the below connecting picture (10):

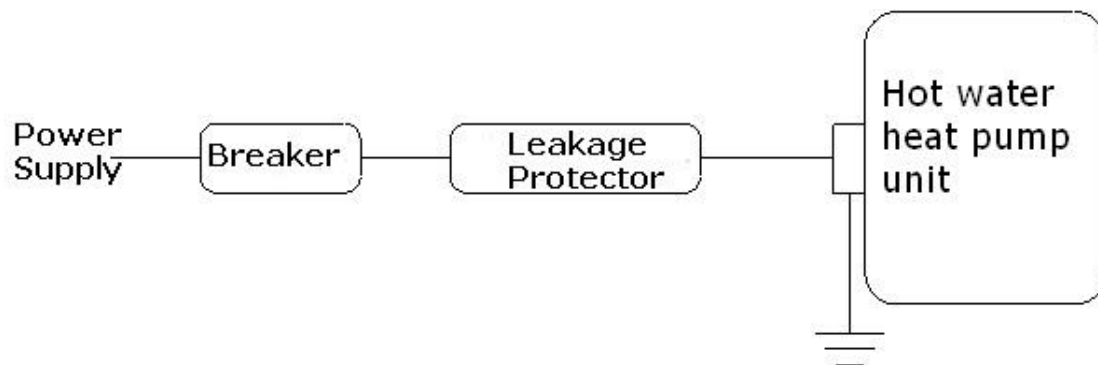

(Picture 10)

Note

- Choose insulated copper core wire for electrical wiring.
- The circuit breaker shall be selected with overload, short circuit protection function, when selected circuit breaker is with three kinds of protection functions of overload, short circuit & leakage, leakage protector can not be installed.

3.13 Wire connecting

Note

- Terminal blocks of the unit of water pumps, auxiliary electrical heating only provide switch signal output, can not be directly driving load, need respectively equipped with AC contactor, thermal relay.



Note

For single phase power supply, if the null wire & fire wire of the power supply

- connect wrongly, the compressor does not start, meanwhile the heat pump controller shows the failure code. change the order of null wire and fire wire, power on again, until failure on the controller be solved, the compressor will start normally.
- For three phases power supply, note for the connecting order of R,S,T. if connecting wrongly, the compressor does not start. the failure and solve solution as same as above.



Note

- As the products are constantly updating and optimizing, if the wiring diagram and stickers of the unit are different with the instruction manual, please refer to the unit wiring diagram and stickers as priority.

OPERATING ILLUSTRATION

4.1. Operation panel

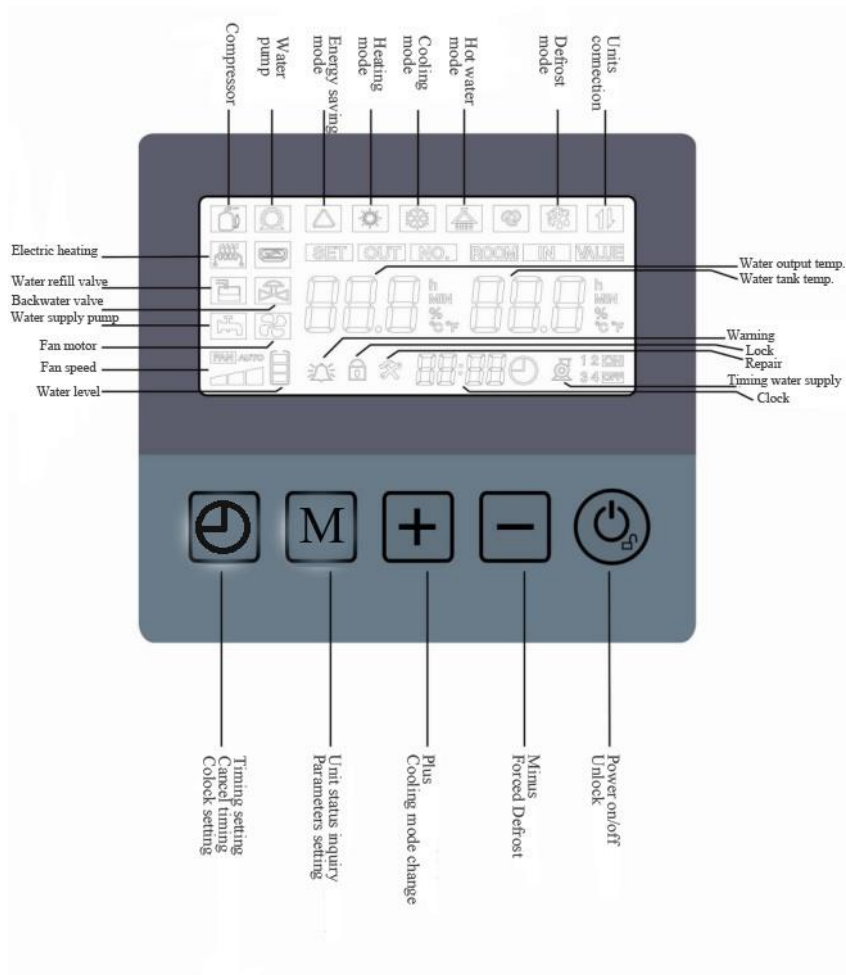

3.2. Wire controller key definition

3.2.1 On / Off key

- * In the unlocked state, long press this key for 1 second to switch on / off the unit;
- * In other setting state, press this key to return to the main interface;
- * When the screen is locked, press this key for 5 seconds to unlock the screen.

3.2.2 Function keys

- * In the main interface, press the function key to enter the unit status query;

3.2.3 The "+" and "-" keys are used

- * Up and down page query, modify parameter values;
- * Combination of "function" key to query and set the parameters

-
- * In power-on state, press "+" and "-" to set the temperature of the current mode.

3.2.4 TIMER key

- * Press and hold the TIMER key for 10 seconds to enter the clock setting state;
- * Press the timer key for entering timing Power on/off setting status, with "+" key or "-" key to set the time 1 and 2 group on / off time;

3.3. Wire controller operation

3.3.1 Parameter query and settings

- * User parameter query and settings (Can set at both of power on or power off status)
 - * In the main interface, press and hold the "FUNCTION" key for 3 seconds to enter the user parameter query interface, then press "-" or "+" to query each parameter;
 - * In the user parameters query interface, press "FUNCTION" to enter user parameters setting interface, press "+" or "-" key to modify the current user parameter value, and then press "FUNCTION" key again to return to the query status;
 - * In the user parameter query or user parameter setting interface, if there is no key operation for 30 seconds, it will exit the user parameter query interface or user parameter setting interface automatically and return to the main interface. Pressing the "POWER" can also return to the main interface.

3.3.2 Factory parameter query and settings (Can set at both of power on or power off status)

- * In the main interface, press the "POWER" key and "+" key for 3 seconds, and enter the factory parameter password interface; in this interface, press the "TIMER" key to switch the password bit, press "+" or "-" can modify the password, press "FUNCTION" for confirmation of the password, if the password is correct then enter into factory parameters query interface (Factory parameter query password: 0814, factory setting password: 8563).
- * In the factory parameter query interface, press "Function" key to enter the current factory parameter setting, press "+" or "-" to modify the current factory parameter value, press "Function" key to return to the query status; ,
- * In factory query or factory parameter setting interface, if there is no key operation for 30 seconds, it will automatically exit the factory parameter query interface or factory parameter setting interface and return to the main interface. Pressing the "POWER" key can also return to the main interface.

3.3.3 Real-time clock setting

- * In the main interface, press the "Timer" button for 5 seconds to enter the real-time clock setting interface;
- * In the real-time clock interface, press the "TIMER" button, the hour part of the number of flashing, then press the "+" key or "-" key, you can set the hours of real-time clock;
- * When the hour part is set, press the "TIMER" key again, then the number of minutes will blink. Press "+" or "-" to set the minute of real time clock.
- * When the minute part is set up, press the "TIMER" key to confirm the real-time clock

setting and return to the main interface.

- * In the real-time clock settings interface, no key operation for 30 seconds, then confirm the current real-time clock settings, and return to the main interface;
- * In the real-time clock setting interface, press the "POWER" key to confirm the current real-time clock setting value and return to the main interface.

3.3.4 Set the timer time for power on/off

- * In the main interface, press the "TIMER" button to enter the timer group settings interface;
- * At this time, press "+" or "-" to set the timing group, 1, 2, 3, 4 and water supply 5 timing groups.
- * When the first group of timing blinking, press "TIMER" key to enter first group timing for booting for HOUR setting interface, the number of HOUR part blinking, press the "+" key or "-" key to set the hour of first part;
- * After setting the HOUR part, then press "TIMER" key again, the number of minute for timing boot blinking, then press "+" key or "-" key, then you can set the minute of first part;
- * After setting the timer 1 group boot minutes, then press the "TIMER" key, then enter the timing of HOUR of first group of shutdown, setting method as same as above;
- * After finishing the setting for shutdown, press "TIMER" key again for confirm and enter the setting for group 2, setting method as same as above, then return to main interface;
- * In the timer setting interface, press and hold the "TIMER" key for 5 seconds to cancel the timing on / off;
- * In the timing interface, if there is no key operation for 30 seconds, confirm the current setting time and return to the main interface. (After power-off, there is memory for it)
- * In the timing interface, press the "POWER" button, then confirm the current setting timing time, return to the main interface;
- * The other groups timing is the same as the first group timer setting.
- * Remark: Timing 1 and 2 timing is timing on / off, timing 3 and 4 are timing water refilling on / off, timing 5 is water supply on/off;

3.3.5 Lock and unlock

- * In the lock key state, press and hold the "POWER" key for 5 seconds, then the buzzer will beep once, cancel locking;
- * Continuous 60 seconds without operation, automatic locking;

3.3.6 Cooling mode

- * When select swimming pool unit or hot water unit, long time press "+" for 5 seconds to switch between cooling and heating / heating hot water;

3.3.7 Forced defrost

- * In the boot state, while long press "-" key for 5 seconds into the forced defrost;
- * Long press "POWER" button, after shutdown, three minutes to completely exit forced defrost; or defrost time to reach the parameter H5 to exit the forced defrost.

3.3.8 Clear History Fault:

* In the interface of query history fault, press "POWER" key and "FUNCTION" key for 5 seconds to clear the stored history fault.

3.3.9 Energy saving mode

* In the power-on state, press and hold the "switch" key and "▼" key for 3 seconds to enter and cancel the power saving mode;

Table 4 (parameter meaning):

22 Temperature setting

o 1	Water tank temperature
o 2	Water inlet temperature
o 3	Water outlet temperature
o 4	Ambient temperature
o 5	Back water temperature
A 1	Exhaust temperature 1#
A 2	Pipe temperature1#
A 3	Gas return temperature1#
A 4	Compressor current 1#
A 5	The expansion valve opening 1#
b 1	Exhaust temperature 2#
b 2	Pipe temperature2#
b 3	Gas return temperature2#
b 4	Compressor current 2#
b 5	The expansion valve opening 2#
c 1	Exhaust temperature 3#
c 2	Pipe temperature3#
c 3	Gas return temperature3#
c 4	Compressor current 3#
c 5	The expansion valve opening 3#
d 1	Exhaust temperature 4#
d 2	Pipe temperature4#
d 3	Gas return temperature4#
d 4	Compressor current 4#
d 5	The expansion valve opening 4#

Note: when choosing single system, it has no abc;

When choosing dual system, it has no cd;

When choosing three systems, it has no d;

When choosing four systems, it has no parameter

4.1 User setting

Under the state of heat pump running (switch on), touch “setting” key for over 3 seconds, when you hear beeping, please remove your hand, the system will enter into setting state. After setting the parameters, finger touches the “setting” key, enter the next parameter setting, exit until all the parameters are set.

Table 5 (parameter setting table):

Code	Parameter name	Adjust range	Initial value (factory set)
L0	Air conditioning return difference temperature	2°C~18°C	3°C
L1	Setting temperature when heating	20°C~parameter F0	55°C
L2	Setting temperature when cooling	8°C~30°C	12°C
L3	Setting temperature when automatic mode	8°C~parameter F0	40°C
L4	Back water temperature difference when hot water mode	2°C~18°C	5°C
L5	Setting temperature when hot water mode	20°C~parameter F0	55°C
L6	Energy-saving heating scheme	0: curve heating 1: different time different water temperature	0
L7	The level setting of curve heating	0~30	10
L8	The slope setting of curve heating	24~50	30
L9	Regular time for first time	00~23	23
L10	Regular time for second time	00~23	6
L11	Regular time for third time	00~23	9
L12	Regular time for fourth time	00~23	17
L13	Setting heating temperature for first time	20°C~parameter F0	35

L14	Setting heating temperature for second time	20°C~parameter F0	42
L15	Setting heating temperature for third time	20°C~parameter F0	30
L16	Setting heating temperature for fourth time	20°C~parameter F0	40
L17	Electric heating	0: no 1: hot water electric heating 2: air conditioner electric heating 3: hot water+air conditioner electric heating	3: hot water+air conditioner electric heating
L18	Ambient temperature allowing electric heater start	0°C~35°C	5°C
L19	Electric heating delayed startup time	0~90Min	30Min
L20	area	0 (wet) / 1 (dry)	1
L21	Extend the defrost cycle of ambient temperature setting point	-30°C~2°C	-10°C
L22	Solar water pump start-up difference set back	3-15°C	10°C
L23	Back water temperature	30°C~65°C	40°C
L24	Supplement water temperature	20°C~60°C	45°C
L25	Compressor current	0~40A	15
L26	Defrosting cycle	20min~90min	45min
L27	Coil pipe temperature to enter defrosting	-15°C~-1°C	-7°C
L28	Maximal defrosting time	5min~20min	8min
L29	Coil pipe temperature to exit defrosting	1°C~40°C	13°C
L30	Enter the defrosting coil and ambient temperature	0°C~30°C	10°C

	difference		
L31	When electric heating, circulation pump chose	0 (do not open) /1 (open)	1 (open)
L32	water pump (cooling/heating/automatic)	0(constant temperature closed)/1 (constant temperature open)	1 (constant temperature open)
L33	Water flow (online)	0 (independent) /1 (sharing)	1 (sharing)
L34	Centralized control scheme	0: efficient 1: energy saving	0: efficient
L35	Module to adjust period	5~150min	20min
L36	Setting ambient temperature To start water pump	-30°C~5°C	-10°C
L37	Circulation water	0 (closed) /1 (open)	0
L38	Back water valve and water pump	0 (closed) /1 (open)	0
L39	Three-way valve	0 (closed) /1 (open)	0

4. 2 Factory setting

Touch "open" key and up key for over 5 seconds, enter the password 0814

code	Parameter name	Adjust range	value	remark
H0	Ambient temperature too low protection	-30°C~0°C	-30°C	
H1	mode	0: hot water 1:heating/cooling/automatic 2: hot water/heating 3: all is ok 4: heating 5: cooling 6: hot water+cooling	3	3
H2	Exhaust temperature is too high to protect set point	80~150°C	105°C	
P	Electronic expansion valve exhaust control back to the	0°C~30°C	10°C	

	differential temperature setting			
P0	Electronic expansion valve action cycle set	20s~90s	30	
P1	Heating target heat setting	-5°C~10°C	5°C	
P2	Ambient temperature \geq 17°C, the minimum open degree of electric expansion	1~30	20	
P3	Expansion valve allows the exhaust temperature during adjustment	80°C~150°C	95°C	
P4	Defrost the electronic expansion valve opening set	1~45	40	*10
P5	When 5°C \leq ambient temperature $<$ 17°C, the minimum open degree of electric expansion	1~30	17	*10
P6	When -2°C \leq ambient temperature $<$ 5°C, the minimum open degree of electric expansion	1~30	12	*10
P7	When -9°C \leq ambient temperature $<$ -2°C, the minimum open degree of electric expansion	1~30	9	*10
P8	Heating mode of electronic expansion valve automatically selected manually	0/1	1	0: manual/1: automatic
P9	The reserved	0/1	1	0: manual/1: automatic
PA	The opening of the largest electronic expansion valve setting	30~48	45	*10
Pb	Ambient temperature $<$ -9°C, the minimum open degree of electric expansion	1~30	8	
F0	Tank mode and heating mode setting temperature limit	50°C~90°C	55°C	
F1	Water inflow temperature setting and display temperature deviation	-5°C~15°C	2°C	
F2	Spray solenoid valve set start exhaust	80~150°C	98°C	
F3	Poor spray solenoid valve back to set	5~40°C	20°C	

F4	Increase enthalpy electromagnetic valve to start the ring temperature setting	-20~20°C	5°C	
F5	The reserved			
U0~Ub	Heating point expansion valve, steps of each point set	1~48	See work table	*10
y0~y8	Refrigeration fixed-point expansion valve, steps of each point set	1~48	See work table	*10

4.3 Special Parameter

Touch “open” key and up key for over 5 seconds, enter the password 8563

code	Parameter name	Setting range	value	remark
F8	Limited lock machine time	0~99	0	According to "week" for the timing of units. "0" for no limit function.

Note

- Recommend user not change the function setting by yourself, otherwise will occur dysfunction.
- If you want to change the parameter setting will need the confirmation of our authorized dealer or after-sales technical personnel.

4.3.3 Error code and alarm:

If there is any fault during heat pump running, will have sound “di..di..” from the controller, operation panel display error code, the controller will lock automatically and stop output, to protect the unit’s parts, see the detailed content in below table 15.

For multiple system unit, if has one system occur error, only lock and stop this system with error, the other system can run normally.

Table 6 (error code and meaning)

21 Table (error and meaning)

code	meaning
E01	Exhaust temperature 1#
E02	Exhaust temperature 2#
E03	Exhaust temperature 3#
E04	Exhaust temperature 4#
E05	Coil pipe temperature 1#
E06	Coil pipe temperature 2#
E07	Coil pipe temperature 3#
E08	Coil pipe temperature 4#

E09	Gas return temperature 1#
E10	Gas return temperature 2#
E11	Gas return temperature 3#
E12	Gas return temperature 4#
E13	
E14	
E15	
E16	
E17	Back water temperature
E18	Water outlet temperature
E19	Water inlet temperature
E20	Water tank temperature
E21	Communication failures
E22	Ambient temperature
E25	Water level
P01	Water flow protection
P02	High pressure protecting 1#
P03	High pressure protecting 2#
P04	High pressure protecting 3#
P05	High pressure protecting 4#
P06	Low pressure protecting 1#
P07	Low pressure protecting 2#
P08	Low pressure protecting 3#
P09	Low pressure protecting 4#
P10	Phase protection
P11	High exhaust temperature protection 1#
P12	High exhaust temperature protection 2#
P13	High exhaust temperature protection 3#
P14	High exhaust temperature protection 4#
P15	Inlet and outlet water temperature difference too big protection
P16	Over cold protection
P17	Antifreeze protection
P18	Electric heating overheating protection
P19	Current protect for compressor 1
P20	Current protect for compressor 2
P21	Current protect for compressor 3
P22	Current protect for compressor 4
P23	When defrost, outlet water temperature too low protection
P24	Fan overload protection



●When the unit occur error,should find out the cause of error,with the right technical method to exclude error,not through the “short circuit”to exclude error,otherwise will cause damage to the unit.

DEBUGGING AND RUNNING

5.1 The preparation work before the test running

(1) Heat pump unit inspection:

- ◇Check whether the appearance of unit and the inside pipe system is damaged during transportation.
- ◇Check whether there is air inside the heat pump water pipe, if any, should empty it by the needle valve on heat pump water pipe, or the air vent valve on the water pump.
- ◇Check whether the fan blades interfere to or touch its fixed plate and shielding cover, make sure no things on or fall into the shielding cover.

(2) Checking Distribution System

- ◇Check whether the power supply complies with the manual and the unit nameplate.
- ◇Check whether all the power and control circuits connect absolutely; the wires connects correctly according to the diagram; reliable grounding, all terminals wiring solid.

(3) Check piping system

- ◇Check whether the piping system, filling pipes, backwater pipes, pressure meter, thermometer, valves, water level switches and other equipment are installed correctly.
- ◇Check whether the valves needed opening are open and those needed closing are well closed.
- ◇Check whether the insulation works of piping system is good.

5.2 Testing running

Units test must be operated by professional person.

- ◇Conduct the overall testing running, until a comprehensive inspection in entire system meets all the requirements.
- ◇Connect to power supply and start the heat pump, the heat pump starts with 3 minutes delay. For the three-phase power supply units, firstly check whether the fan and the water pump rotate direction is correct. If incorrect, please cut off power supply and adjust the phase sequence. Measure the compressor running current, check if the compressor has abnormal sound.
- ◇Check whether the unit meets the requirements, run whole system for some time (normally 3 days), if all are fine, then can be put into normal operation.

TROUBLE SHOOTING

When heat pump unit appears problem, please contact professional maintenance personnel. When maintenance personnel deal with the problems, please refer to below table 7 to exclude error.

Fault condition	The possible cause of the malfunction	Treatment measures
Unit no operating	<ul style="list-style-type: none"> ✧ Power supply fault ✧ Unit power cable loose ✧ Control power fuse fusing 	<ul style="list-style-type: none"> ✧ Cut off power supply and check the power supply ✧ Pinpoint the cause and fix ✧ Replace the fuse
Water pump operation but water not circulating or water pump noise too large	<ul style="list-style-type: none"> ✧ Shortage of water in water systems ✧ Water systems with air ✧ Water system valve is not completely open ✧ Water filter dirty and blacking 	<ul style="list-style-type: none"> ✧ Check the system water refilling device, and refill water to system. ✧ Exclude the air in water systems ✧ Open the valves completely in water system ✧ Clean water filters
Low heating capacity of the unit	<ul style="list-style-type: none"> ✧ Insufficient of refrigerant ✧ Insulation of water system is not good ✧ Dry filter plugging ✧ Air heat exchanger poor heat dissipation ✧ Lack of water flow 	<ul style="list-style-type: none"> ✧ System leakage checking and refrigerant charging ✧ Strengthen the water system insulation ✧ Replace the filter ✧ Clean air heat exchanger ✧ Cleaning water filters
Compressor no operation	<ul style="list-style-type: none"> ✧ Power failure ✧ Compressor contactor damage ✧ Loose wiring ✧ Compressor over heat protection ✧ Outlet water temperature is too high ✧ Lack of water flow 	<ul style="list-style-type: none"> ✧ Pinpoint the causes of power failure ✧ Replace the contactor ✧ Loose points to identify and fix ✧ Find out the reason of overheat problem, before restart ✧ Reset outlet water temperature ✧ Clean water filters and empty the air inside system
Compressor operating with large noise	<ul style="list-style-type: none"> ✧ Liquid preparation goes into the compressor ✧ Damage of compressor internal parts ✧ Wrong phase sequence ✧ Insufficient lubricating oil 	<ul style="list-style-type: none"> ✧ Check whether the throttling device and fan are good ✧ Replace the compressor ✧ Adjust to the correct phase sequence ✧ Add lubricating oil

<p>No operation of fan</p>	<ul style="list-style-type: none"> ✧ Fan fixing screws loose ✧ Fan motor burning ✧ Capacitance of fan is damage 	<ul style="list-style-type: none"> ✧ Fastening the fixing screws ✧ Replace the motor or fan ✧ Replace the capacitance
<p>Compressor operation, but the unit no heating</p>	<ul style="list-style-type: none"> ✧ Refrigerant leaks completely ✧ Compressor failure 	<ul style="list-style-type: none"> ✧ System leakage checking and refrigerant charging ✧ Replace the compressor
<p>Protection of unit water flow is too low</p>	<ul style="list-style-type: none"> ✧ System is lack of water flow ✧ Target water flow switch not reset 	<ul style="list-style-type: none"> ✧ Clean water filter and empty the air in system ✧ Adjust or replace the target flow switch
<p>System high pressure is too large</p>	<ul style="list-style-type: none"> ✧ Water flow is not enough ✧ The heat exchanger of heat source side scaling ✧ Refrigerant too much ✧ Refrigerant way system has non-condensable gas 	<ul style="list-style-type: none"> ✧ Check water systems, increase water flow ✧ Clean the heat exchanger ✧ Remove extra refrigerant ✧ Remove non-condensable gas
<p>System low pressure is too low</p>	<ul style="list-style-type: none"> ✧ Filter plugging ✧ Pressure drop that goes by the heat exchanger is too big ✧ Insufficient wind capacity 	<ul style="list-style-type: none"> ✧ Replace the filter ✧ Check if the throttle device is normal ✧ Check if fan is normal

MAINTENANCE

The heat pump is a more automatic equipment needing inspection regularly. If the maintenance is long-term and effective, the operation reliability and the service life will be greatly increased. Maintenance must be operated by qualified persons.

1. Clean the water filter regularly to ensure the clean water in system and avoid the damage caused by its blocking.
2. When use and maintain the heat pump unit, please noted that all safety protection and parameters are pre-set by factory, do not change at random.
3. Always check whether the power unit and electrical system cable is solid, and there are no abnormal movements between electrical components. If required carry out time maintenance and replacement.
4. Check the filling valve of water system, safety valve of water tank, liquid level controller and safety valve works normally to avoid air into the system due to water quantity decrease, thus affecting the heating capacity and the reliability of unit.
5. Check whether the water pump and water valve are working properly, check whether the water pipeline or pipe fittings have the problem of leakage.
6. Keep units in a clean, dry and well ventilated environment, also regularly clean (1-2 months) the fin evaporator with clean water to keep good heat absorption (turn the power off when cleaning).
7. Checking whether the components of units working properly, check whether the unit pipe connectors and air valves are with oil, make sure no leakage.
8. To avoid blocking of the fan outlet, around the unit should be kept clean and dry, well ventilated.
9. Drain the water, cut off the power and put a protective cover, if the downtime is long. A comprehensive checking is necessary before using the unit again.
10. Please contact the local special maintenance department of our company for the repairs if you cannot solve failures.
11. About the condenser cleaning, our company recommend adopt 50°C~60°C, the concentration of 15% thermal phosphoric acid solution to clean the condenser, start the unit with circulation pump to clean 3 hours, finally rinse with water for 3 times.(when installation the pipe, please use reversed tee interface, using a plug seal interface) with the pipe connection. Corrosive cleaning material to clean the condenser is banned.

12.The tank needs to be in use after a period of time (generally for two months, depending on the local water quality).



Note

- Clean the heat source side heat exchanger by professional personnel.
- When using cleaner,should according to dirt deposition to adjust the concentration of cleaner,cleaning place and cleaning time and so on.
- After cleaning,need to deal with waste liquid.
- After using cleaner,use clear water to clean water pipe and heat exchanger,do water treatment to prevent water system corrosion or the dirt water readsorption
- Because some cleaner has corrosion damage to skin,eyes etc,so the protection device must be used in the cleaning process(gloves,mask and gobe etc.)

WARRANTY SERVICES

1. The free warranty of our air source heat pump is 24 months from the date of purchase. The after-sale service department of our company will provide consumers free services due to the failure of the product quality under warranty.

2. Warranty certificate:

The heat pump units are free to repair during the warranty period, if the users have the purchase invoice and products warranty card, and the product number is same as the warranty card number.

If not, the units are regarded as products surpassing the warranty period. These products are not a free warranty service - the company can provide paid services for users.

3 The damages caused below are not in the free warranty coverage, but our company could provide paid service.

- a. Damage due to the consumer installing, dismantling and repairing.
- b. Damage due to transportation and maintenance by consumer themselves, or not Using referring to the manual.
- c. Failure due to power supply not meet requirements, or due to natural disasters.
- d. Failure due to the dirty of the outdoor exchanger and the water system, also the irregular clearing the exchanger and filter.
- e. Not properly equipping filter for the refilling cold water pipe and water inlet pipe.
- f. Equipment failure caused by forced running for large water production seriously exceeds the heat pump capacity.
- g. The warranty card number of the product maintained does not match the product number.
- h. Warranty card altered with an eraser or revised.
- i. No warranty card and purchase invoices.
- j. Over warranty period products.

4. Warranty Process

- a. After installation the unit, debugging qualified, please fill in (warranty card), and submit sheet A to the installation company.
- b. Warranty card sheet B is the necessary proof of warranty for free warranty service, please keep it well.
 - c. Please fill in the content neatly which is needed on warranty card, in order that our Company can provide service for you.

GENERAL SCHEMATIC AND BASIC DESCRIPTION

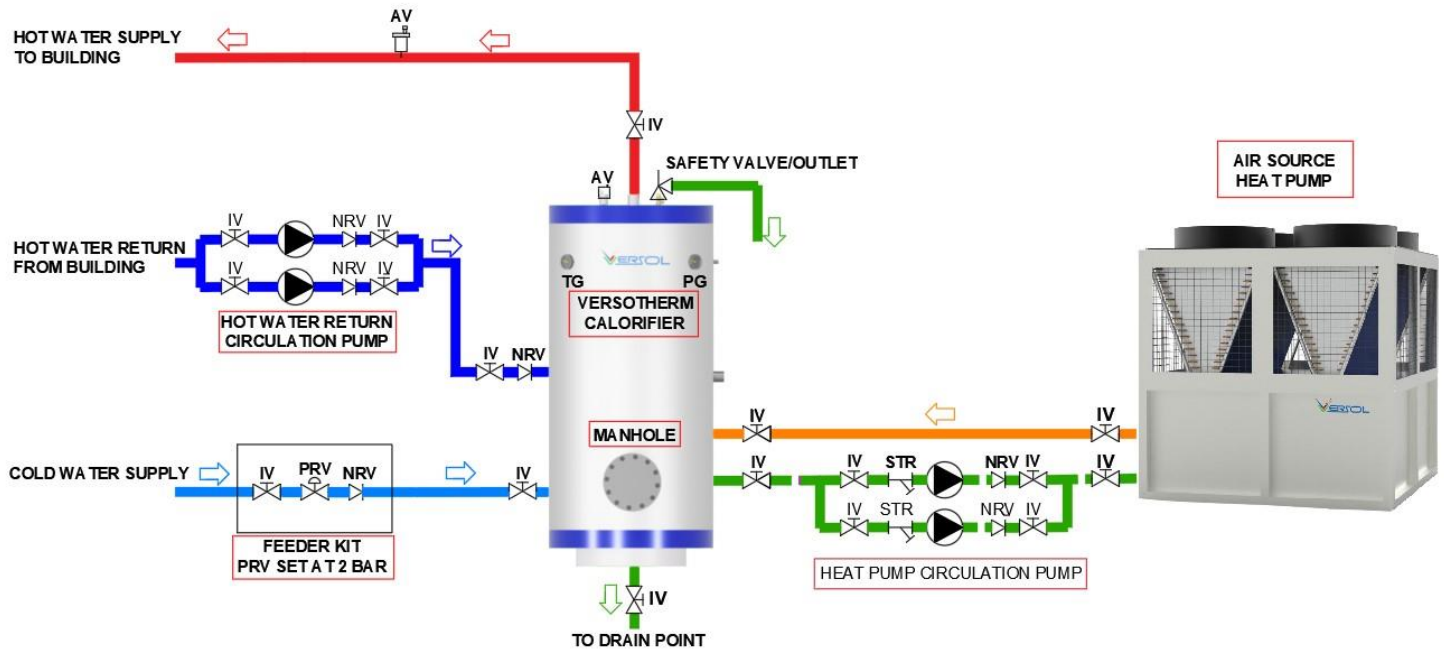

Cold water supply will enter and fill the storage calorifier where the water is stored and getting heated up (by Air Source Heat Pump).

From storage calorifier water will travel to the air source heat pump through circulation pump, heated up water from air source heat pump will go back to the storage calorifier thus creating a continuous loop up until hot water temperature in the storage calorifier is reach as per required / set temperature.

Whenever the water temperature in the storage calorifier is less than 5°C of set temperature (example 60°C), Air source heat pump and heat pump circulation pump will turn on and heat up the water in the storage calorifier to the required / set temperature.

Heat Pump circulation pump will shift operation based on timer, which can be set at from 15 min to 8 hr.

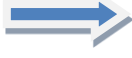
BASIC AIR SOURCE HEAT PUMP OPERATION MODE		
If storage calorifier temperature is $\leq 55^{\circ}\text{C}$		Heat Pump = ON (Duty) Heat Pump Circulation Pump-1 ON (Duty)
If storage calorifier temperature is $= 60^{\circ}\text{C}$		Heat Pump = OFF Heat Pump Circulation Pump-1 = OFF

NOTE: Heat Pump hot water heating item quantity, system description, control philosophy, sequence of operation and control logic may vary.



Versol Poland | Versol Italy | Versol UK | Versol USA | Versol Middle East | Versol India

